

## Section 2

# Hybrid System Operation

**Overview** The Toyota hybrid system has two drive sources: the gasoline engine and the electric motor. The hybrid control system selects the best combination of those two power sources depending on driving conditions.

- The '01-'03 Prius uses THS (Toyota Hybrid System).
- The '04 & later Prius uses THS-II, which carries over the same basic concepts as the previous model but offers improvements to MG1 and MG2, the battery and engine.

### Hybrid System Components

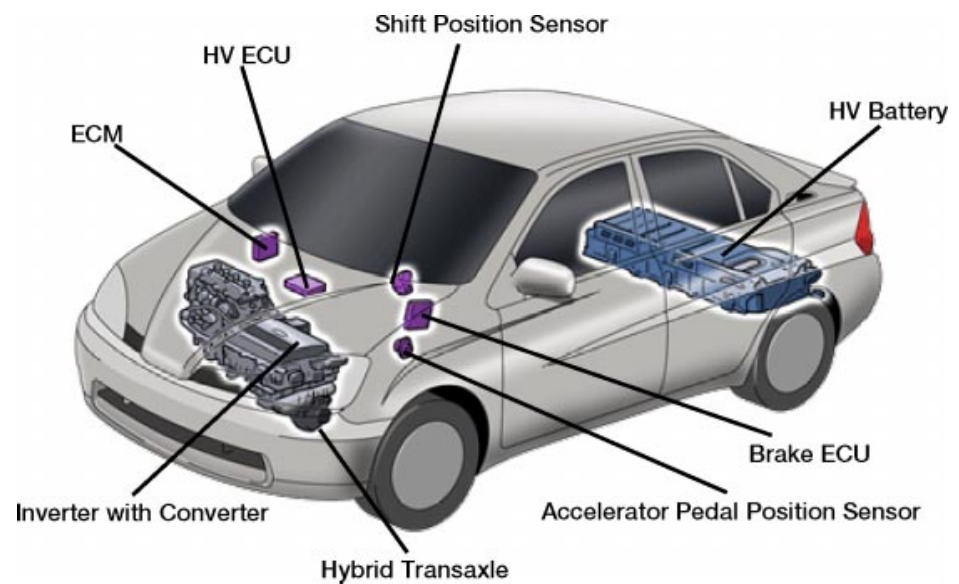

Figure 2.1

T072f002c



**Safety Procedures** Incorrectly performed hybrid system repairs could cause electrical shock, battery leakage or even an explosion. Be sure to perform the following safety procedures whenever servicing the hybrid vehicle's high-voltage system or hybrid control system:

- Remove the key from the ignition. If the vehicle is equipped with smart key, turn the smart key system off.
- Disconnect the negative (-) terminal of the auxiliary battery.
- Wear insulated gloves.
- Remove service plug and put it in your pocket.
- **Do not make any repairs for five minutes.**

If the key cannot be removed from the key slot (for instance, because of body damage during an accident) be sure to perform the following procedures:

- Disconnect the auxiliary battery.
- Remove the HEV fuse (20A yellow fuse in the engine compartment junction block.) When in doubt, pull all four fuses in the fuse block.

**NOTE**

High-voltage insulated gloves can be ordered from the Toyota SPX/OTC SST catalog under part numbers:

**Small gloves – 00002-03100-S**

**Medium gloves – 00002-03200-M**

**Large gloves – 00002-03300-L**

To check the integrity of the glove's surface, blow air into the glove and fold the base of the glove over to seal the air inside. Then, slowly roll the base of the glove towards the fingers.

- If the glove holds pressure, its insulating properties are intact.
- If there is an air leak, high-voltage electricity can find its way back through that same hole and into your body! Discard the glove(s) and start over until you have a pair of gloves that can fully protect you from the vehicle's high-voltage circuits.

**WARNING**

After disabling the vehicle, power is maintained for 90 seconds in the SRS system and for five minutes in the high-voltage electrical system. If any of the disabling steps above cannot be performed, proceed with caution as there is no assurance that the high-voltage electrical system, SRS or fuel pumps are disabled. Never cut orange high-voltage power cables or open high-voltage components.

**WARNING**

Due to circuit resistance, it takes at least five minutes before high-voltage is discharged from the inverter circuit. Even after five minutes have passed, the following safety precautions should be observed:

- Before touching an orange high-voltage cable, or any other cable that you cannot identify, use the tester to confirm that the voltage in the cable is 12V or less.
- After removing the service plug, cover the plug connector using rubber or vinyl tape.
- After removing a high-voltage cable, be sure to cover the terminal using rubber or vinyl tape.
- Use insulated tools when available.
- Do not leave tools or parts (bolts, nuts, etc.) inside the cabin.
- Do not wear metallic objects. (A metallic object may cause a short-circuit.)

**Submerged Vehicle Safety**

Many fire departments and police stations have been trained to safely remove hybrid vehicles from water in case of an emergency. Always call your local fire department in this situation.

To safely handle a Prius that is fully or partially submerged in water, disable the high-voltage electrical system and SRS airbags. Remove the vehicle from the water. Drain the water from the vehicle if possible. Then, follow the extrication and vehicle disable procedures below:

- Immobilize the vehicle.
- Chock the wheels and set the parking brake.
- Remove the key from the key slot.
- If equipped with smart key, use the smart cancel switch underneath the steering column to disable the system.
- Keep the electronic key at least 16 feet (5 meters) away from the vehicle.
- Disconnect the 12V auxiliary battery.
- Remove the HEV fuse in the engine compartment. When in doubt, pull all four fuses in the fuse block.

**Service Plug**

('01-'03 Prius)

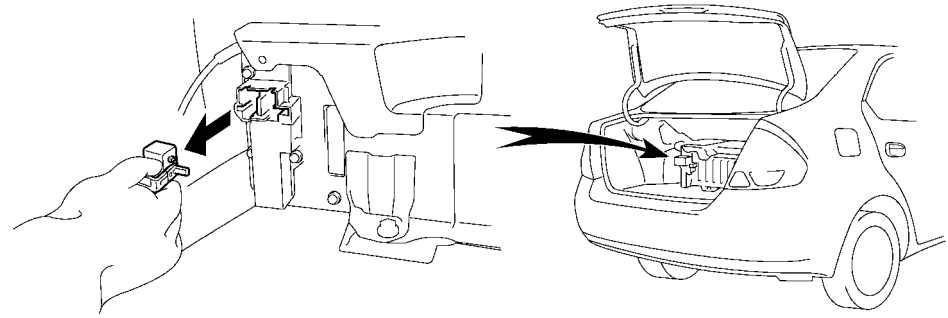

Figure 2.3

T071f203c

**Service Plug**

('04 &amp; later Prius)

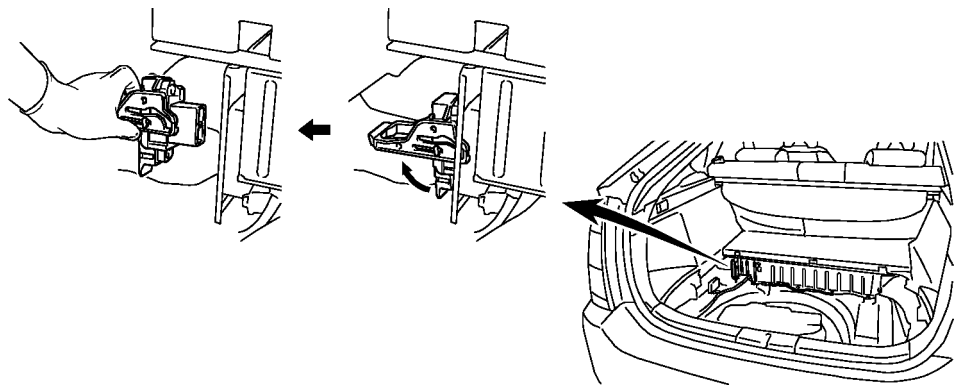

Figure 2.4

T071f204c

**Hybrid Transaxle** The hybrid transaxle contains:

- Motor Generator 1 (MG1) that generates electrical power.
- Motor Generator 2 (MG2) that drives the vehicle.
- A planetary gear unit that provides continuously variable gear ratios and serves as a power splitting device.
- A reduction unit consisting of a silent chain, counter gears and final gears.
- A standard 2-pinion differential

The '01-'03 Prius uses the P111 hybrid transaxle.

The '04 & later Prius uses the P112 hybrid transaxle. The P112 is based on the P111, but offers a higher RPM range, V-shaped permanent magnets in the rotor of MG2, and a newly designed over-modulation control system.

**Hybrid Transaxle**

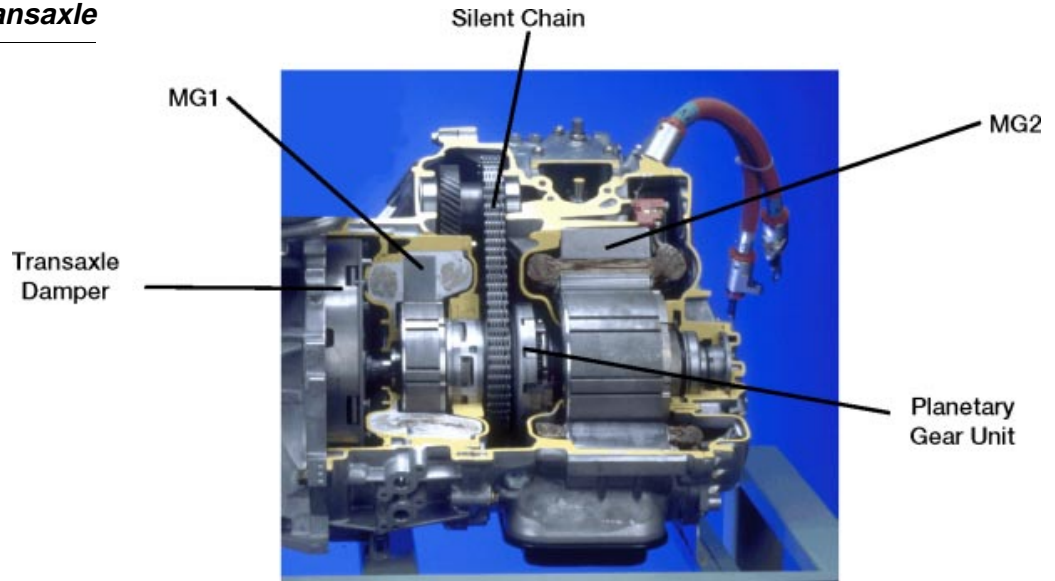

Figure 2.5

T071f205p

**Transaxle Damper** The transaxle damper uses a spring coil with low torsional characteristics. In the '04 & later Prius, the spring rate characteristics of the coil spring have been reduced further to improve its vibration absorption performance and the shape of the flywheel has been optimized for weight reduction.

**Transaxle Damper**

The transaxle damper, which transmits the drive force of the engine to the transaxle, contains a torque fluctuation adsorption mechanism that uses a dry, single plate friction material.



Figure 2.6

T071f206p

<b>Hybrid Transaxle Specifications</b>		'04 Model	'03 Model
		Transaxle Type	P112
Planetary Gear	The No. of Ring Gear Teeth	78	←
	The No. of Pinion Gear Teeth	23	←
	The No. of Sun Gear Teeth	30	←
Differential Gear Ratio		4.113	3.905
Chain	Number of Links	72	74
	Drive Sprocket	36	39
	Driven Sprocket	35	36
Counter Gear	Drive Gear	30	←
	Driven Gear	44	←
Final Gear	Drive Gear	26	←
	Driven Gear	75	←
Fluid Capacity	Liters (US qts, Imp qts)	3.8 (4.0, 3.3)	4.6 (4.9, 4.0)
Fluid Type		ATF WS or equivalent	ATF Type T-IV or equivalent

**MG1 & MG2 Motor Generator 1 & Motor Generator 2**

MG1 and MG2 function as both highly efficient alternating current synchronous generators and electric motors. MG1 and MG2 also serve as sources of supplemental motive force that provide power assistance to the engine as needed.

<b>MG1 and MG2 Specifications</b>		MG1 Specifications	'04 Model	'03 Model
		Item		
Type		Permanent Magnet Motor		
Function		Generate, Engine Starter		
Maximum Voltage	[V]	AC 500	AC 273.6	
Cooling System		Water-cooled		
		MG2 Specifications	'04 Model	'03 Model
Item				
Type		Permanent Magnet Motor		
Function		Generate, Engine Starter		
Maximum Voltage	[V]	AC 500	AC 273.6	
Maximum Output	kW (PS) / rpm	50 (68) / 1,200 ~ 1,540	33 (45) / 1,040 ~ 5,600	
Maximum Torque	N•m (kgf•m) / rpm	400 (40.8) / 0 ~ 1,200	350 (35.7) / 0 ~ 400	
Cooling System		Water-cooled		

Figure 2.7

T071f207c

**MG1 Description** MG1 recharges the HV battery and supplies electrical power to drive MG2. In addition, by regulating the amount of electrical power generated (thus varying MG1's internal resistance and rpm), MG1 effectively controls the transaxle's continuously variable transmission. MG1 also serves as the engine starter.

**MG2 Description** MG2 and the engine work together to drive the wheels. The addition of MG2's strong torque characteristics help achieve excellent dynamic performance, including smooth start-off and acceleration. During regenerative braking, MG2 converts kinetic energy into electrical energy, which is then stored in the HV battery.

**NOTE** Towing a damaged Prius with its front wheels on the ground may cause MG2 to generate electricity. If that happens, the electrical insulation could leak and cause a fire. Always tow the vehicle with the front wheels off of the ground or on a flat bed.

**Planetary Gear Unit** The planetary gear unit is used as a power splitting device. The sun gear is connected to MG1, the ring gear is connected to MG2, and the planetary carrier is connected to the engine output shaft. The motive force is transmitted from the chain drive sprocket to the reduction unit via a silent chain.

**Planetary Gear Connection**

Item	Connection
Sun Gear	MG1
Ring Gear	MG2
Carrier	Engine Output Shaft

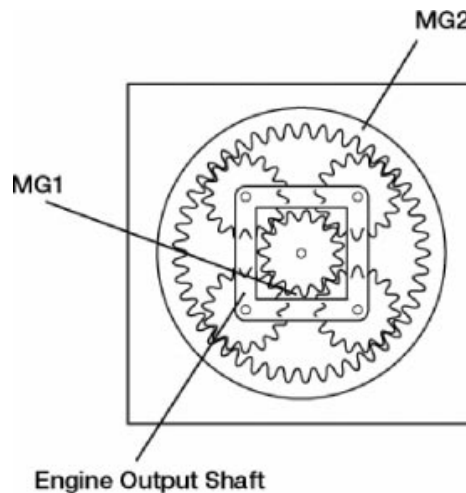

Figure 2.8

T072f035



**Reduction Unit** The reduction unit consists of the silent chain, counter gears and final gears. A silent chain with a small pitch width ensures quiet operation. The overall length has been reduced in contrast to the gear-driven mechanism. The counter gear and final gear teeth have been processed through high-precision honing and their tooth flanks have been optimized to ensure extremely quiet operation.

### ***Reduction Unit***

The final gears have been optimized to reduce the distance between the engine's center shaft and the differential shaft, resulting in a more compact transmission.

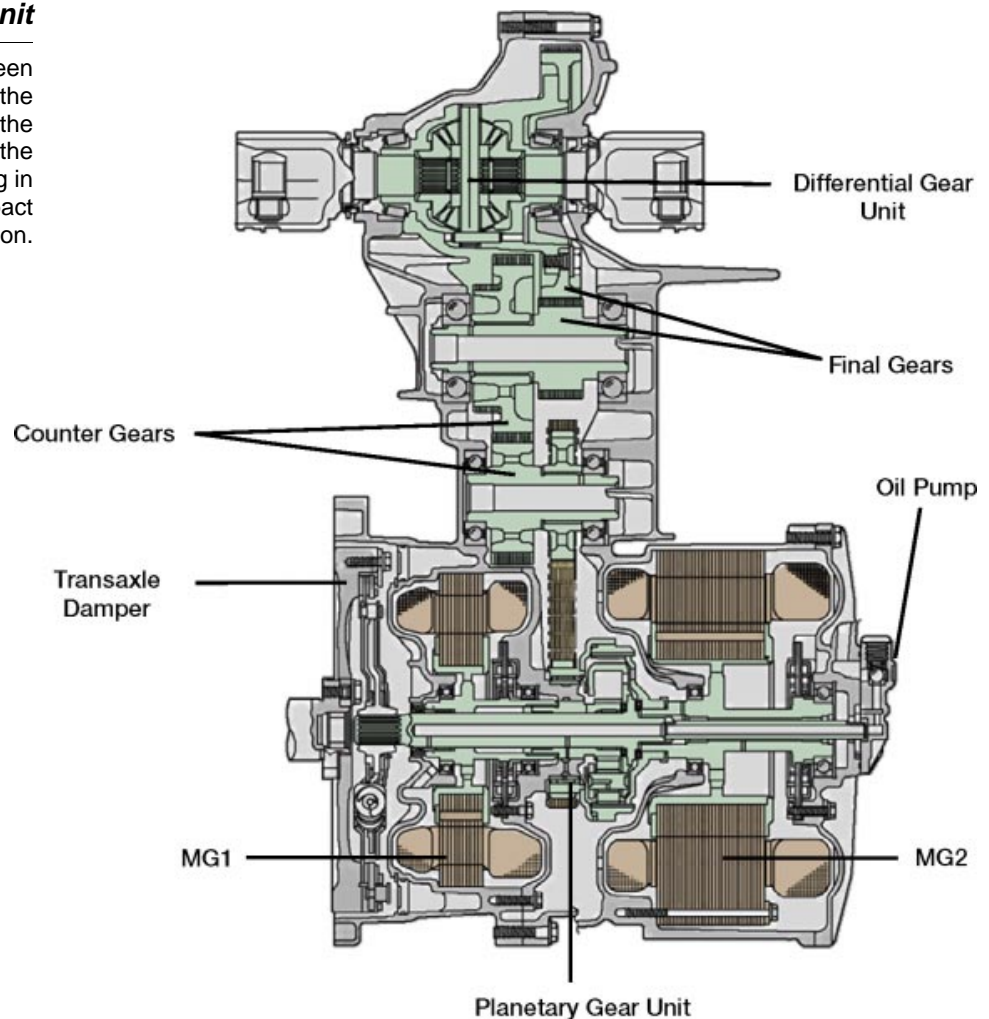

Figure 2.9

T071f209c

**Permanent Magnet Motor**

When three-phase alternating current is passed through the windings of the stator coil, a rotating magnetic field is created. When the rotation of this magnetic field is properly timed in relationship to the rotor, the magnetic field pulls the permanent magnets housed inside the rotor in a circle, causing the rotor to turn and creating the motor's torque. The generated torque is proportionate to the amount of current passing through the stator coils and the rotational speed is controlled by the frequency of the three-phase alternating current.

A high level of torque can be generated efficiently at all speeds by properly controlling the rotating magnetic field and the angles of the rotor magnets.

On the '04 & later Prius the built-in permanent magnets have been changed to a V-shaped structure to improve both power output and torque.

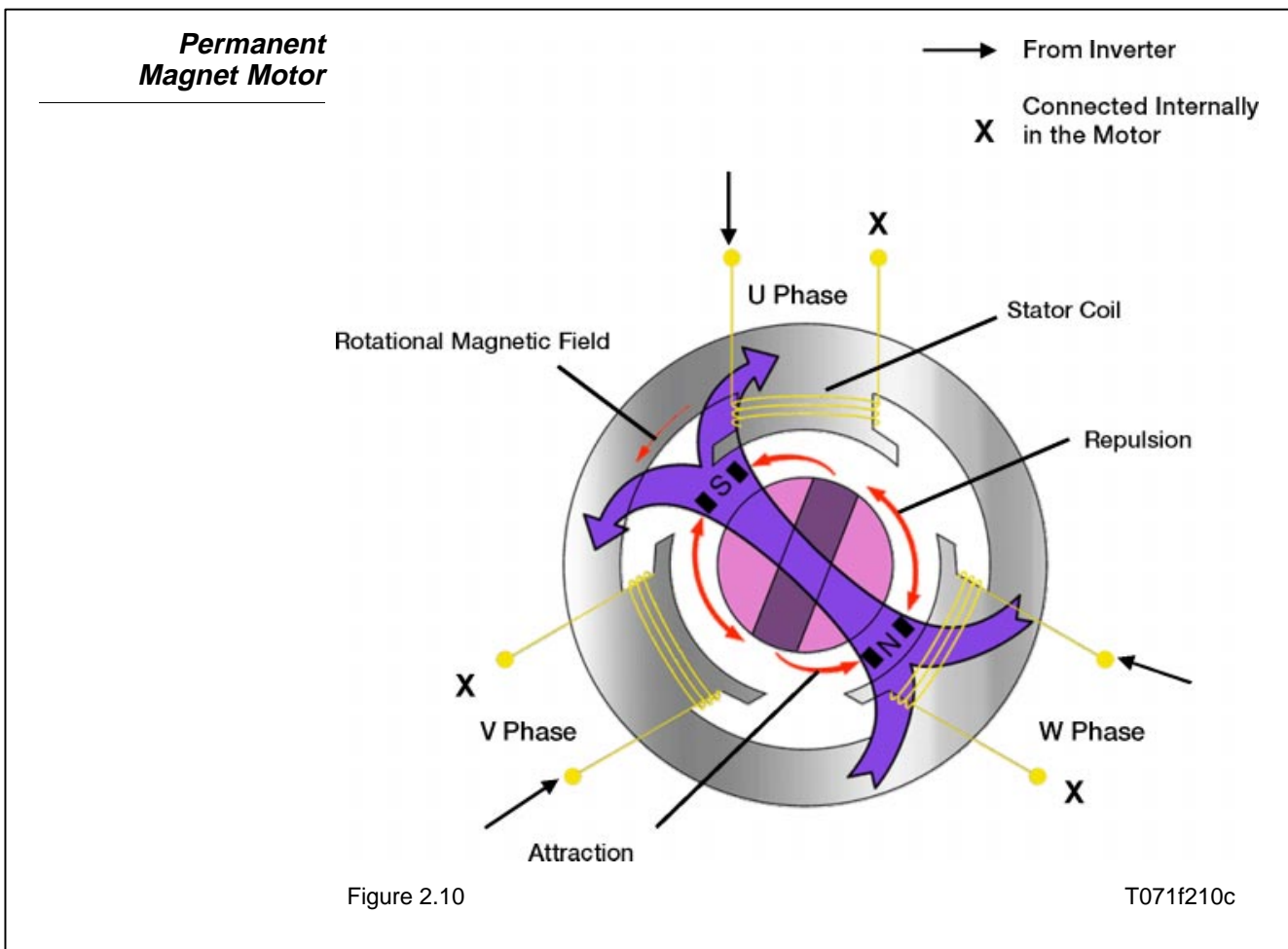

**Permanent Magnet Structure**

The V-shaped structure of the magnets in the '04 & later model provides about 50% more power than previous models.

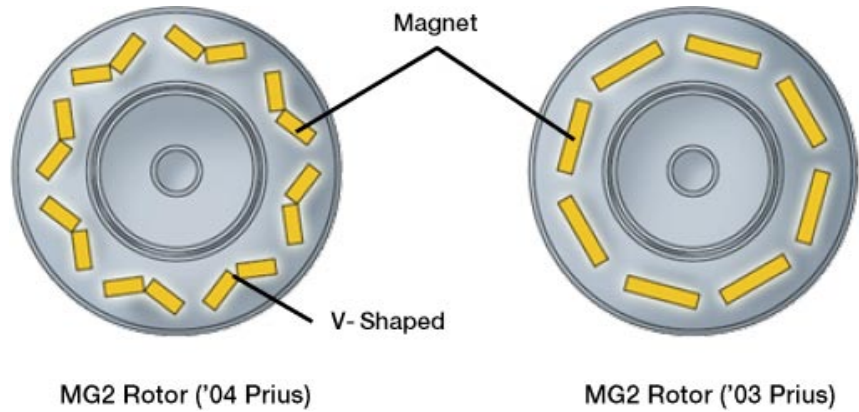

Figure 2.11

T071f211c

**Speed Sensor (Resolver)**

This reliable and compact sensor precisely detects the magnetic pole position, which is essential for the control of MG1 and MG2.

The sensor's stator contains three coils. Since the rotor is oval, the gap between the stator and the rotor varies with the rotation of the rotor.

In addition, the HV ECU uses this sensor as an rpm sensor, calculating the amount of positional variance within a predetermined time interval.

**Speed Sensor (Resolver) Operation**

Output coils B and C are electrically staggered 90 degrees. Because the rotor is oval, the distance of the gap between the stator and the rotor varies with the rotation of the rotor. By passing an alternating current through coil A, output that corresponds to the sensor rotor's position is generated by coils B and C. The absolute position can then be detected from the difference between these outputs.

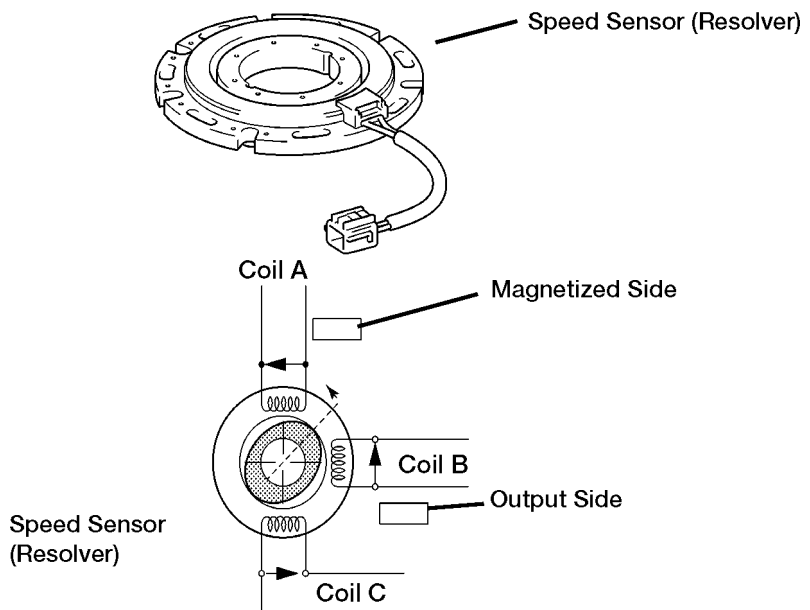

Figure 2.12

T071f212

***Inverter Assembly***

('04 &amp; later Prius)



Figure 2.13

T071f213p

**Inverter** The inverter changes high-voltage direct current from the HV battery into three-phase alternating current for MG1 and MG2. The HV ECU controls the activation of the power transistors. In addition, the inverter transmits information that is needed to control current, such as the output amperage or voltage, to the HV ECU.

The inverter, MG1, and MG2, are cooled by a dedicated radiator and coolant system that is separate from the engine coolant system. The HV ECU controls the electric water pump for this system. In the '04 & later Prius, the radiator has been simplified and the space it occupies has been optimized.

**Boost Converter ('04 & later Prius)** The boost converter boosts the nominal voltage of 201.6V DC that is output by the HV battery to the maximum voltage of 500V DC. To boost the voltage, the converter uses a boost IPM (Integrated Power Module) with a built-in IGBT (Insulated Gate Bipolar Transistor) for switching control, and a reactor to store the energy.

When MG1 or MG2 acts as a generator, the inverter converts the alternating current (range of 201.6V to 500V) generated by either motor into direct current, then the boost converter drops the voltage to 201.6V DC to charge the HV battery.

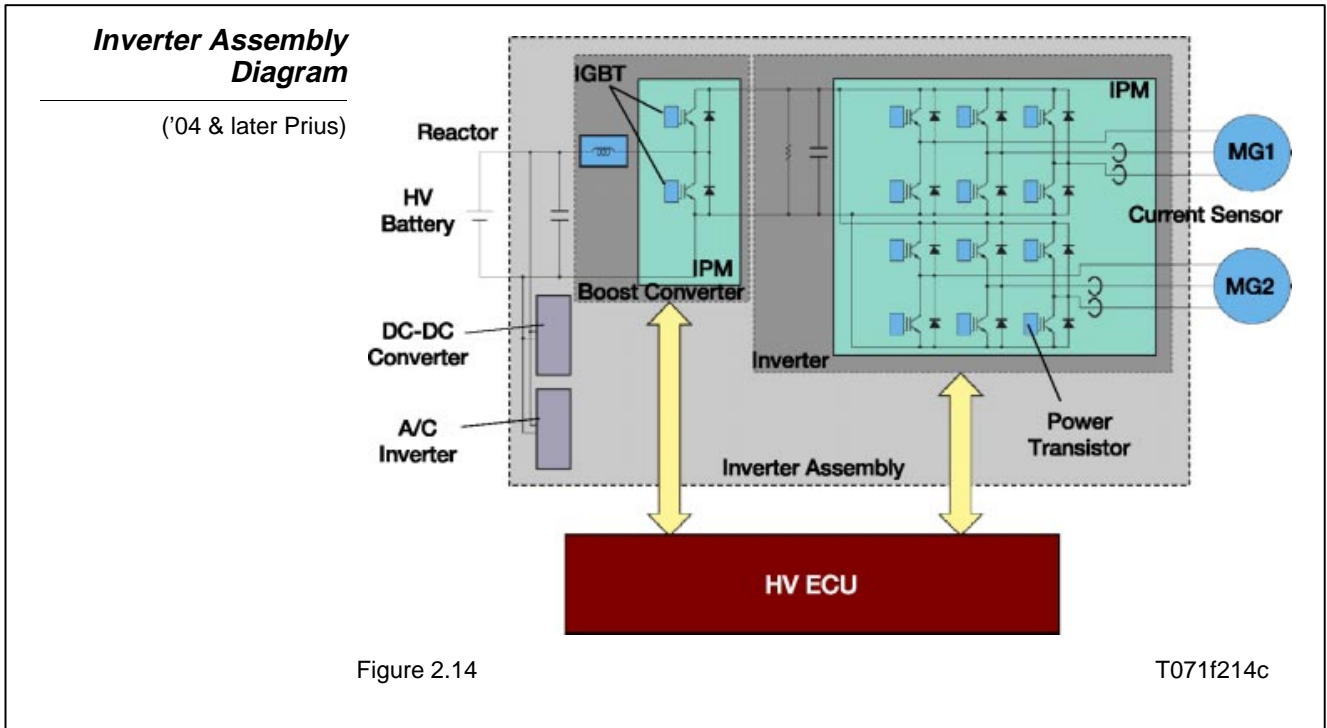

**Converter** The vehicle's auxiliary equipment (such as lights, audio system, A/C cooling fan, ECUs, etc.) is powered by standard 12V DC.

On the '01-'03 Prius, the THS generator voltage is 273.6V DC. A converter transforms the voltage from 273.6V DC to 12V DC to recharge the auxiliary battery.

On the '04 and later Prius, the THS-II generator outputs a nominal voltage of 201.6V DC. The converter transforms the voltage from 201.6V DC to 12V DC to recharge the auxiliary battery.

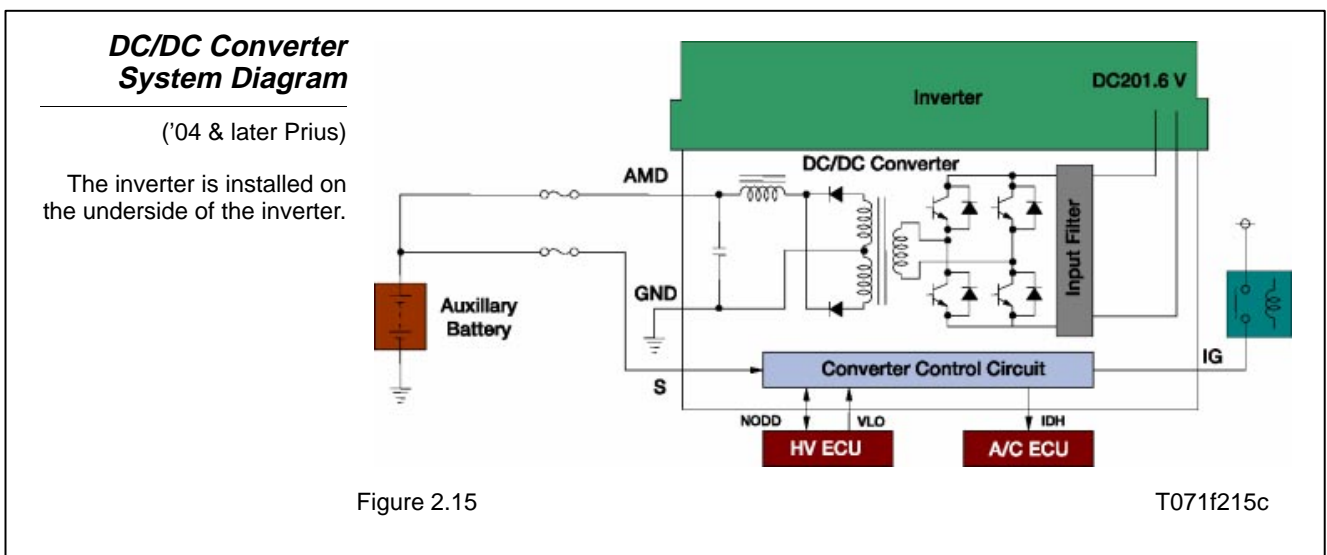

**A/C Inverter ('04 & later Prius)** The inverter assembly includes a separate inverter for the air conditioning system that changes the HV battery's nominal voltage of 201.6V DC into 201.6V AC to power the air conditioning system's electric inverter compressor.

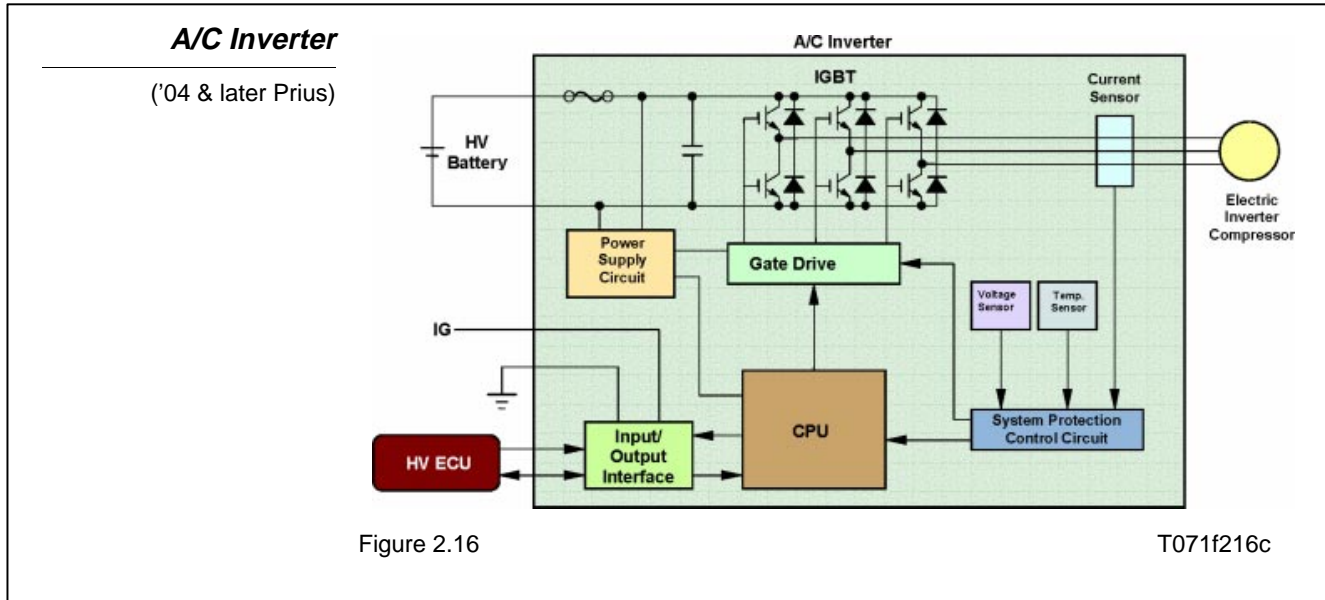

### Cooling System for Inverter, MG1 and MG2

A dedicated cooling system uses a water pump to cool the inverter, MG1 and MG2. It is separate from the engine cooling system. This cooling system activates when the power supply is switched to IG.

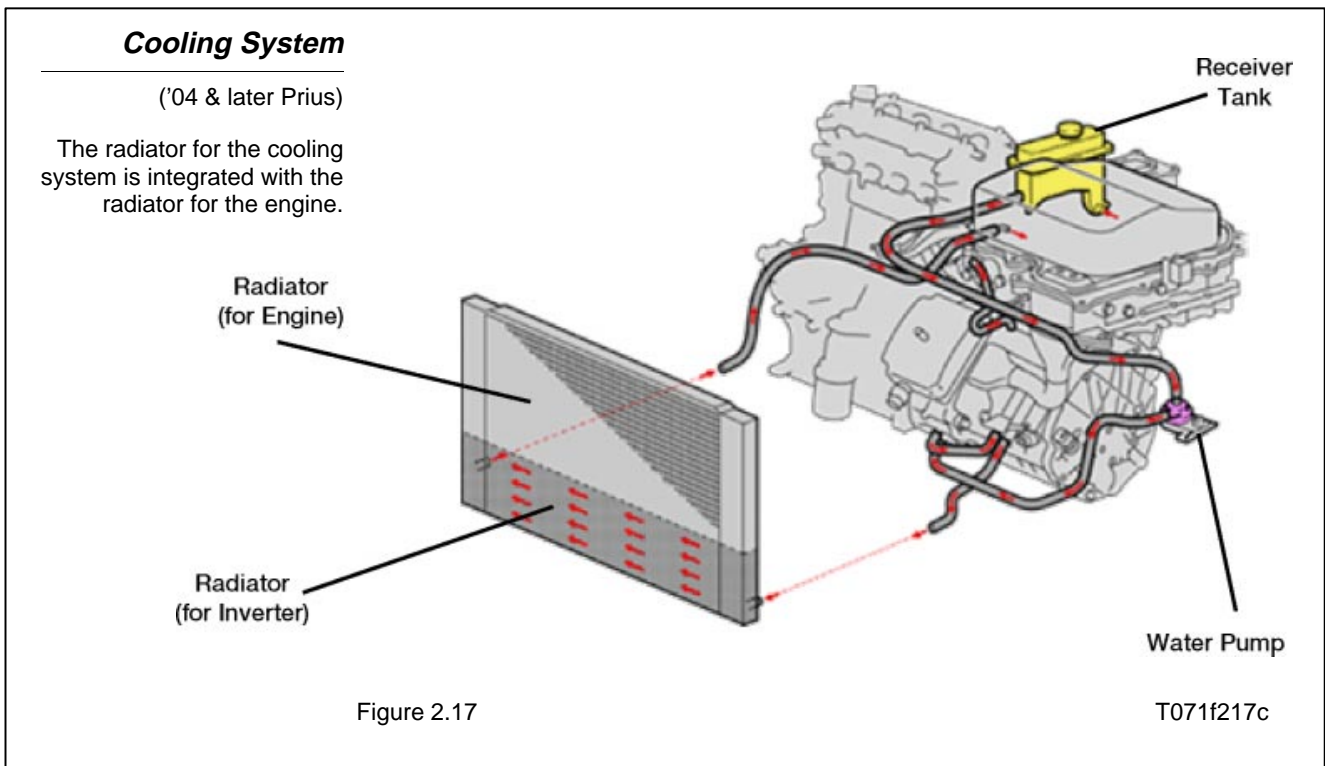

### HV ECU The HV ECU:

- Controls MG1, MG2 and the engine based on torque demand, regenerative brake control and the HV Battery’s State of Charge (SOC). These factors are determined by the shift position, the degree with which the accelerator is depressed and vehicle speed.
- The HV ECU monitors HV Battery SOC and the temperature of the HV battery, MG1 and MG2.
- To ensure reliable circuit shutdown and protect the vehicle’s circuits from high-voltage, the HV ECU uses three relays housed in the System Main Relay assembly to connect and disconnect the high-voltage circuit.
- If the HV ECU detects a malfunction in the hybrid system, it will control the system based on the data that is stored in its memory.

**Nomographs** A nomograph is a kind of chart that conveys the relationship between different sets of numbers. The hybrid operation nomographs below convey the relationship between RPM for MG1, MG2 and the engine.

Because MG1, MG2 and the engine are mechanically connected in the Planetary Gear Set, if one of the components changes rpm, the rpm of the other components will be affected. So in the nomograph, the rpm values of the 3 power sources maintain a relationship in which they are always connected by a straight line.

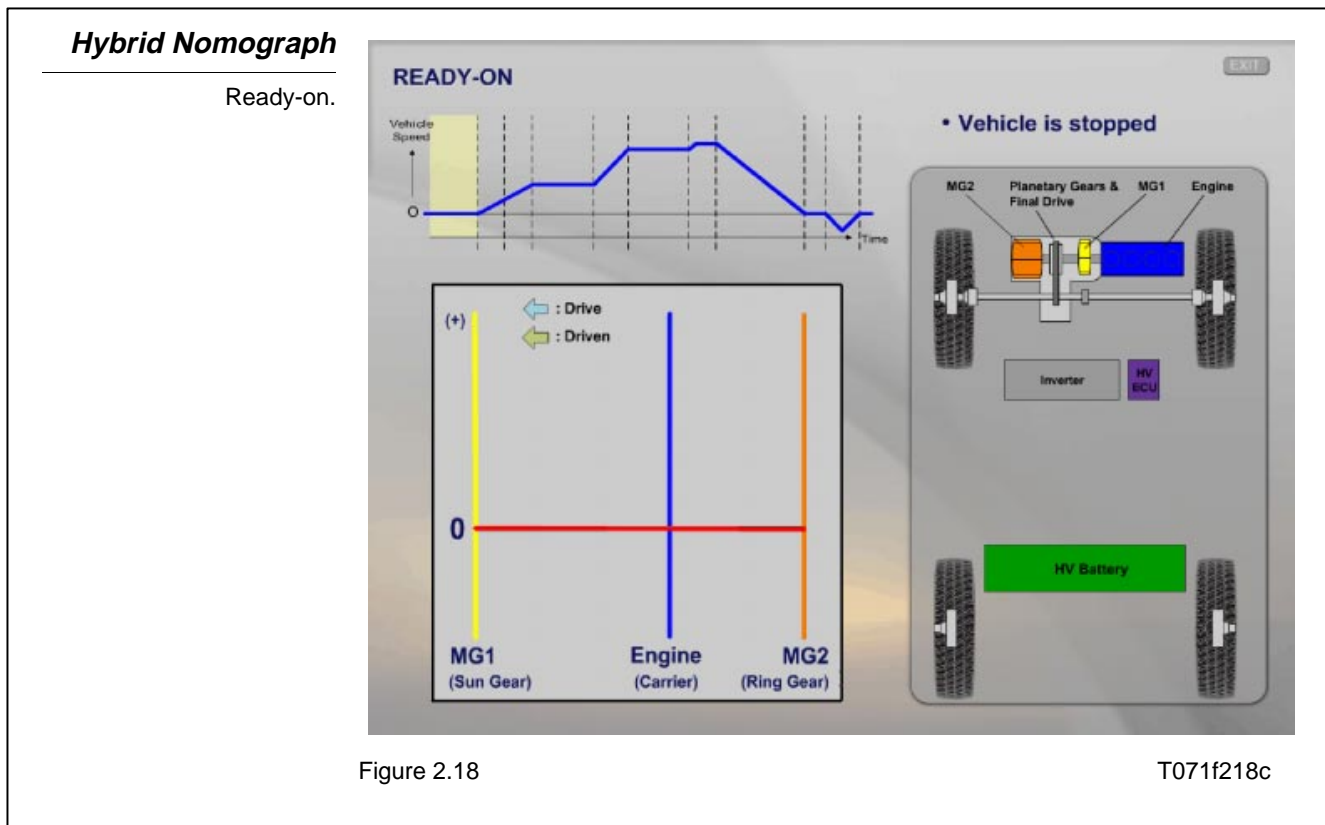



**Hybrid Nomograph**

Starting out.

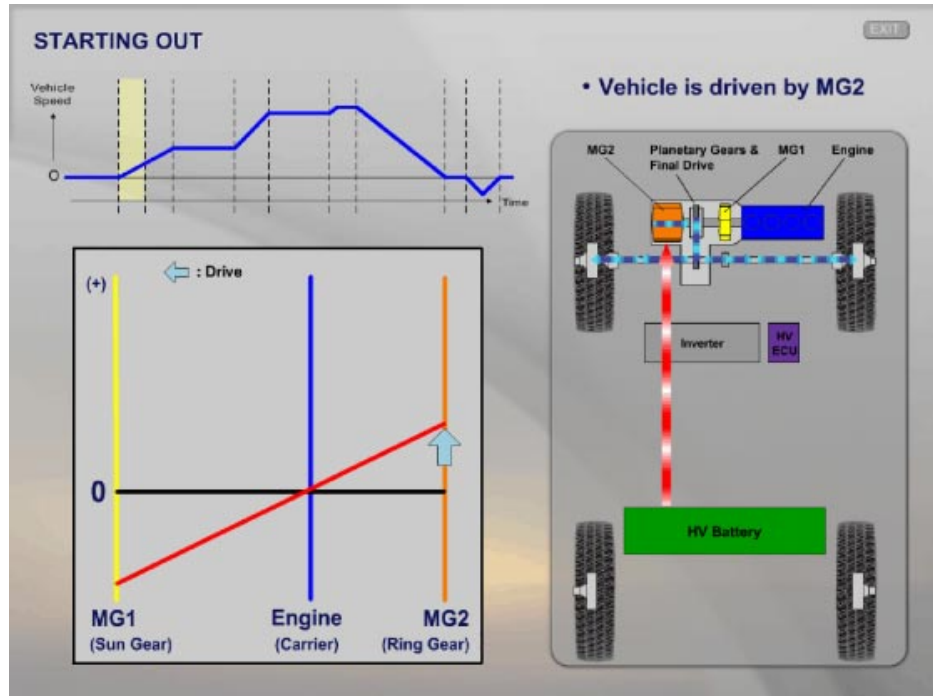

Figure 2.19

T071f219c

**Hybrid Nomograph**

Engine starting.

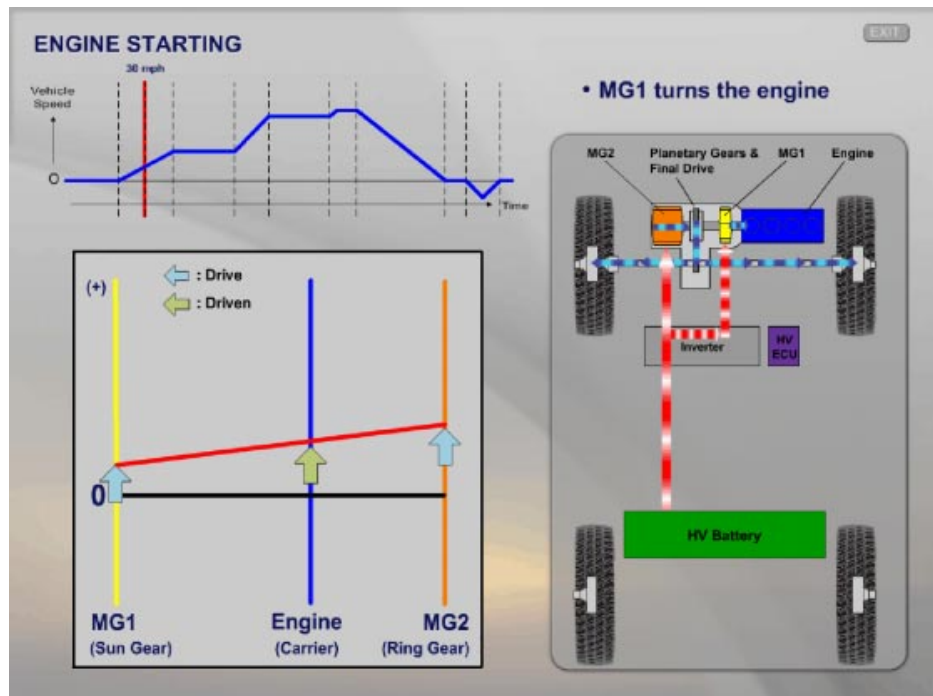

Figure 2.20

T071f220c

**Hybrid Nomograph**

Light acceleration with engine.

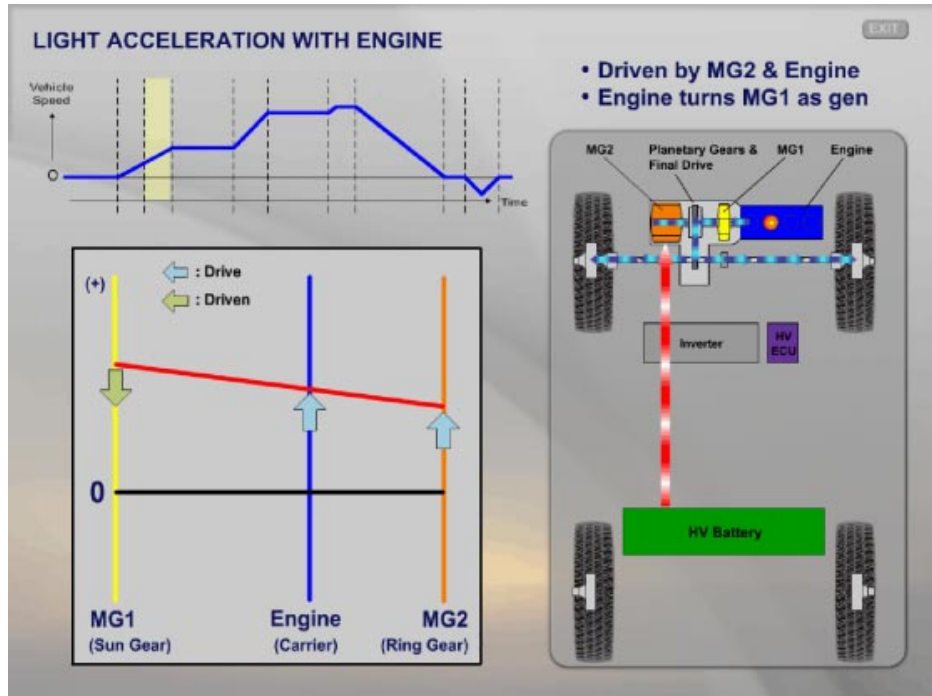

Figure 2.21

T071f221c

**Hybrid Nomograph**

Low speed cruising.

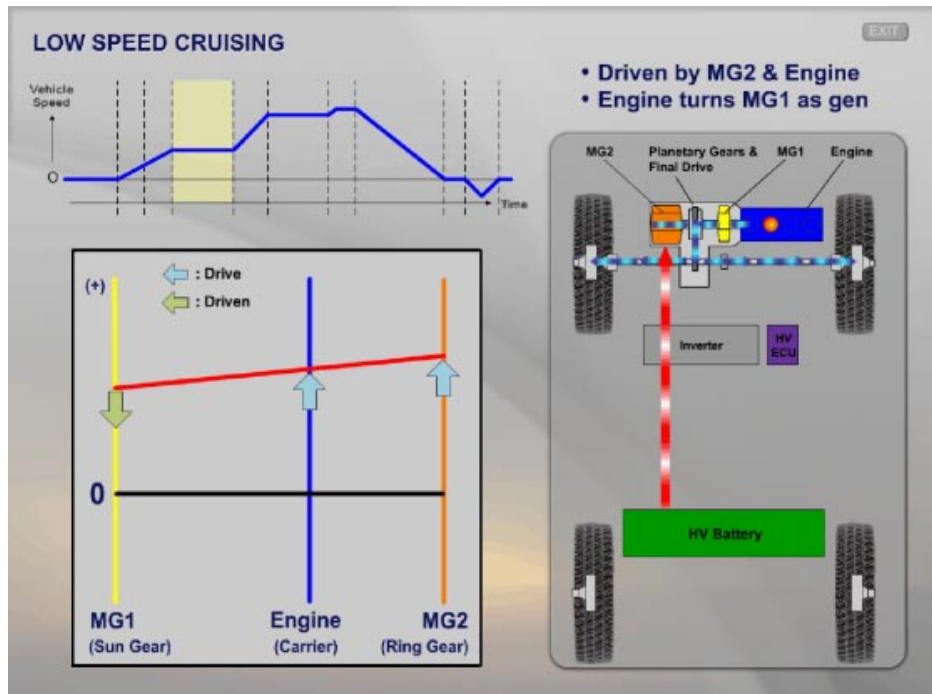

Figure 2.22

T071f222c

**Hybrid Nomograph**

Full acceleration.

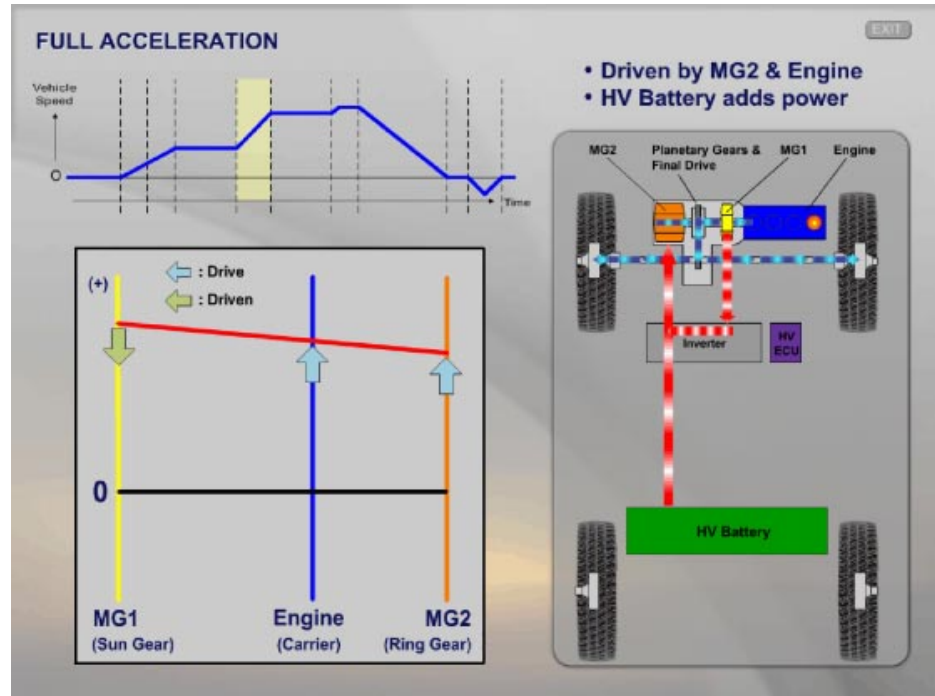

Figure 2.23

T071f223c

**Hybrid Nomograph**

High speed cruising.

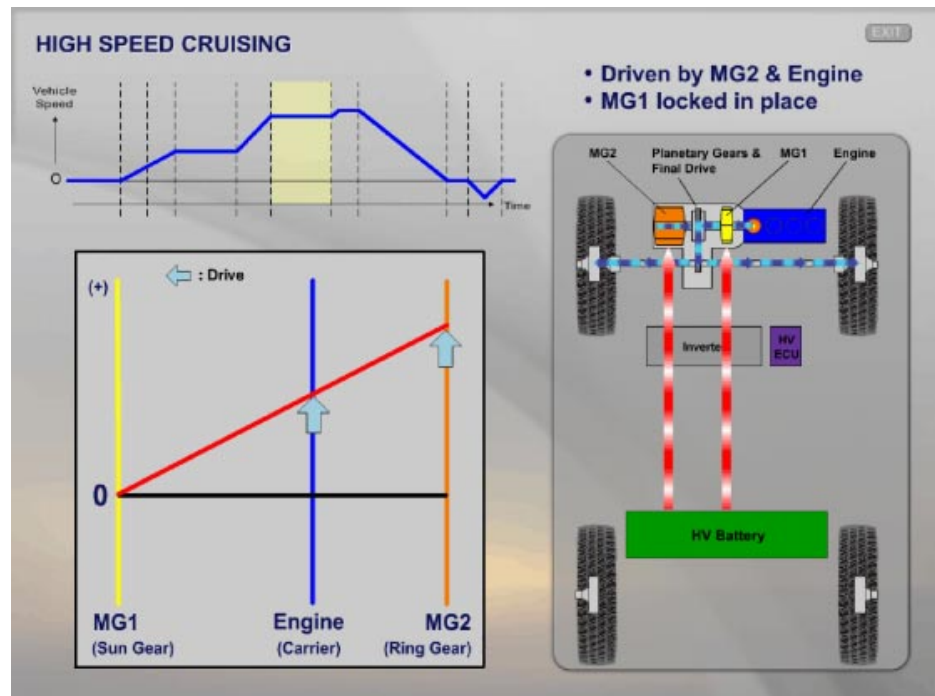

Figure 2.24

T071f224c

**Hybrid Nomograph**

Max speed.

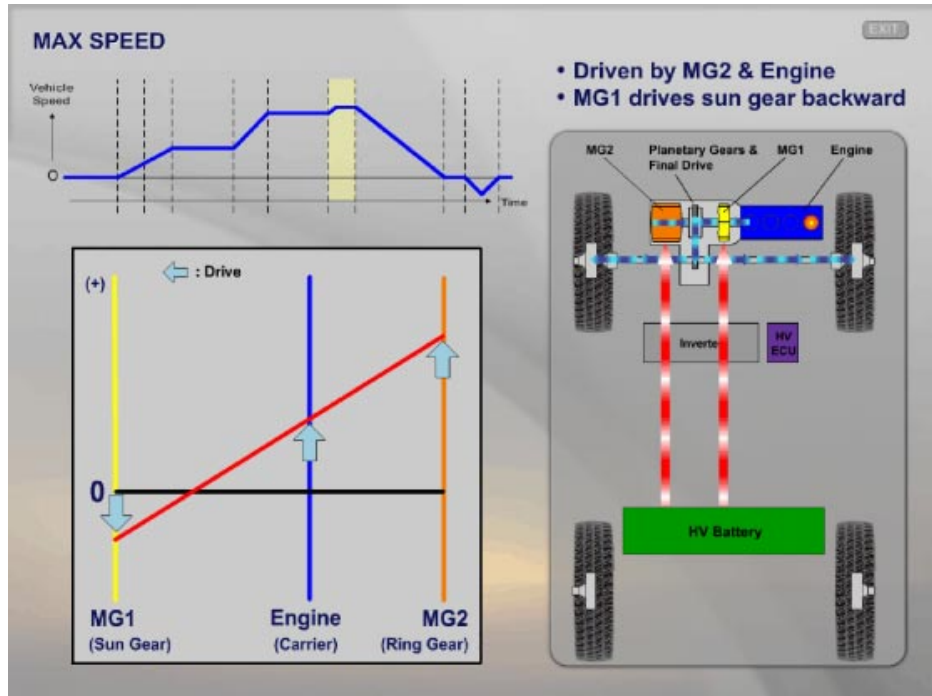

Figure 2.25

T071f225c

**Hybrid Nomograph**

Deceleration or braking.

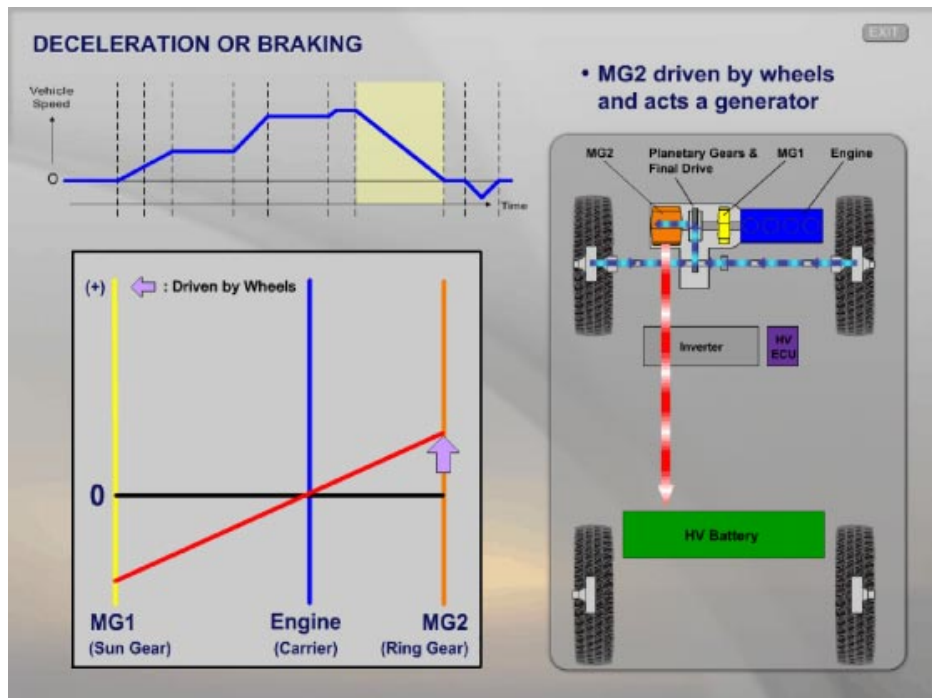

Figure 2.26

T071f226c

**Hybrid Nomograph**

Reverse.

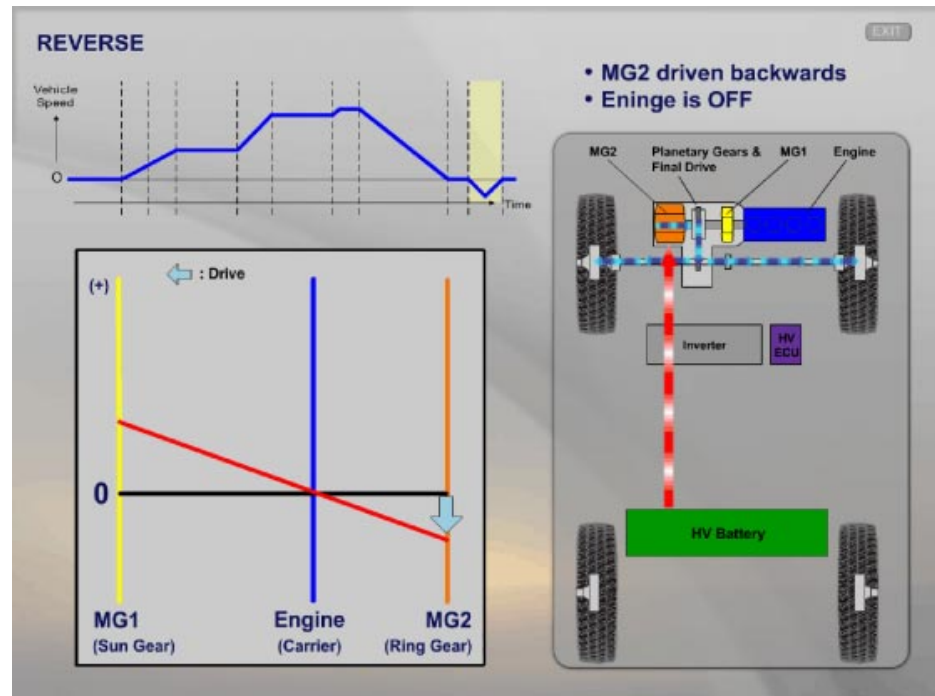

Figure 2.27

T071f227c

**Using Information Codes**

Information Codes are a three-digit supplement to HV ECU DTCs. They provide additional information and freeze frame data to help diagnose the vehicle's condition. These codes can be found on the Diagnostic Tester **HV ECU** menu. Use the screen flow shown below to access the codes. For a detailed description of each Information Code, refer to the DI section of the Repair Manual.

### Accessing Information Codes

Follow the screen flow to access the Information Codes.

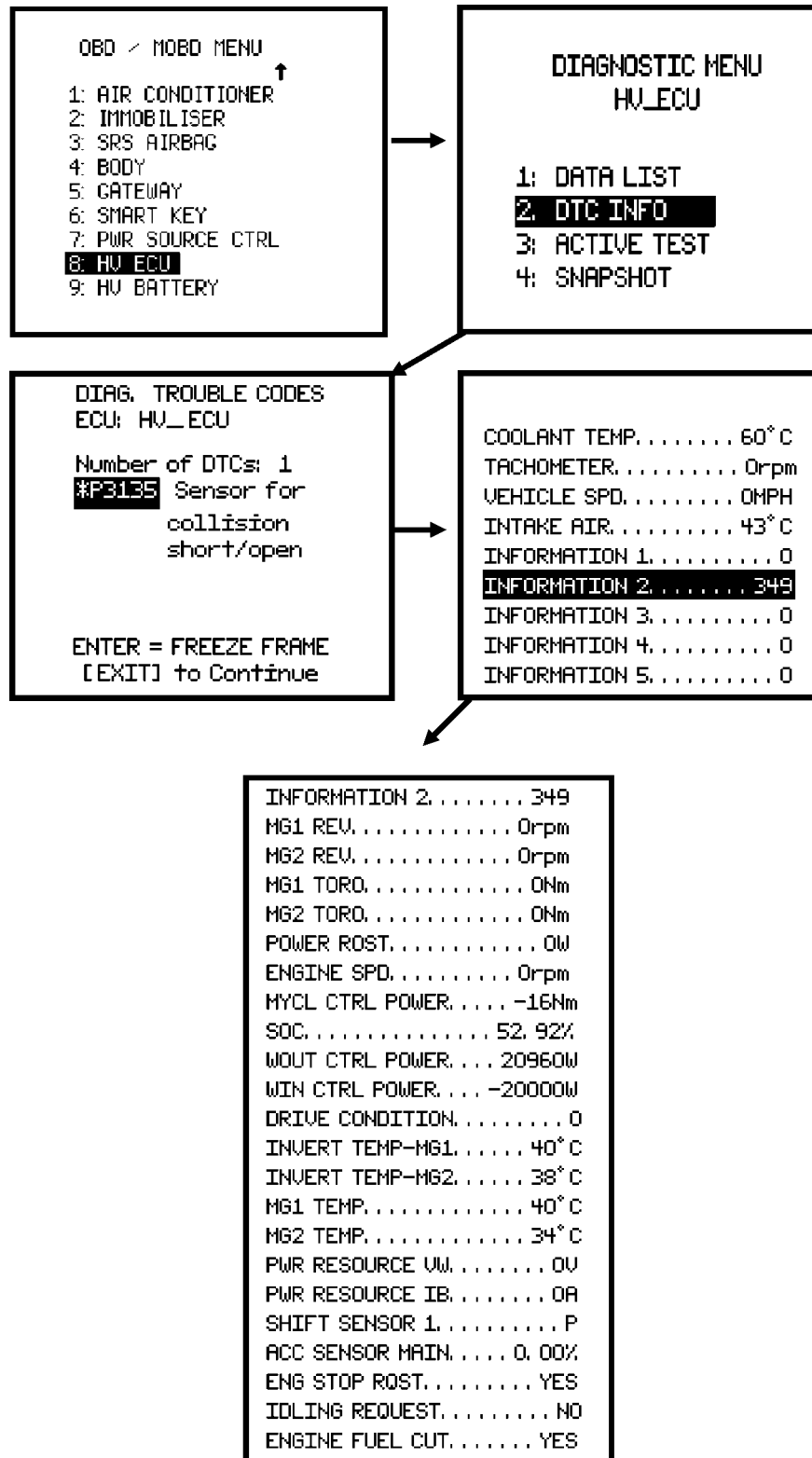

Figure 2.28

T071f228