

Overview of the Fuel Delivery System

The fuel delivery system incorporates the following components:

- 1) Fuel tank (with evaporative emissions controls)
- 2) Fuel pump
- 3) Fuel pipe and in line filter
- 4) Fuel delivery pipe (fuel rail)
- 5) Pulsation damper (many engines)
- 6) Fuel injectors
- 7) Cold start injector (most engines)
- 8) Fuel pressure regulator
- 9) Fuel return pipe

Fuel is pumped from the tank by an electric fuel pump, which is controlled by the circuit opening relay. Fuel flows through the fuel filter to the **fuel rail (fuel delivery pipe)** and up to the pressure regulator where it is held under pressure. The pressure regulator maintains fuel pressure in the rail at a specified value above intake manifold pressure. This maintains a constant

pressure drop across the fuel injectors regardless of engine load. Fuel in excess of that consumed by engine operation is returned to the tank by way of the fuel return line. A pulsation damper, mounted to the fuel rail, is used on some engines to absorb pressure variations in the fuel rail due to injectors opening and closing.

The fuel injectors, which directly control fuel metering to the intake manifold, are pulsed by the ECU. The ECU completes the injector ground circuit for a calculated amount of time referred to as injection duration or injection pulse width. The ECU determines which air/fuel ratio the engine runs at based upon engine conditions monitored by input sensors and a program stored in its memory.

During cold engine starting, many engines incorporate a cold start injector designed to improve startability below a specified coolant temperature.

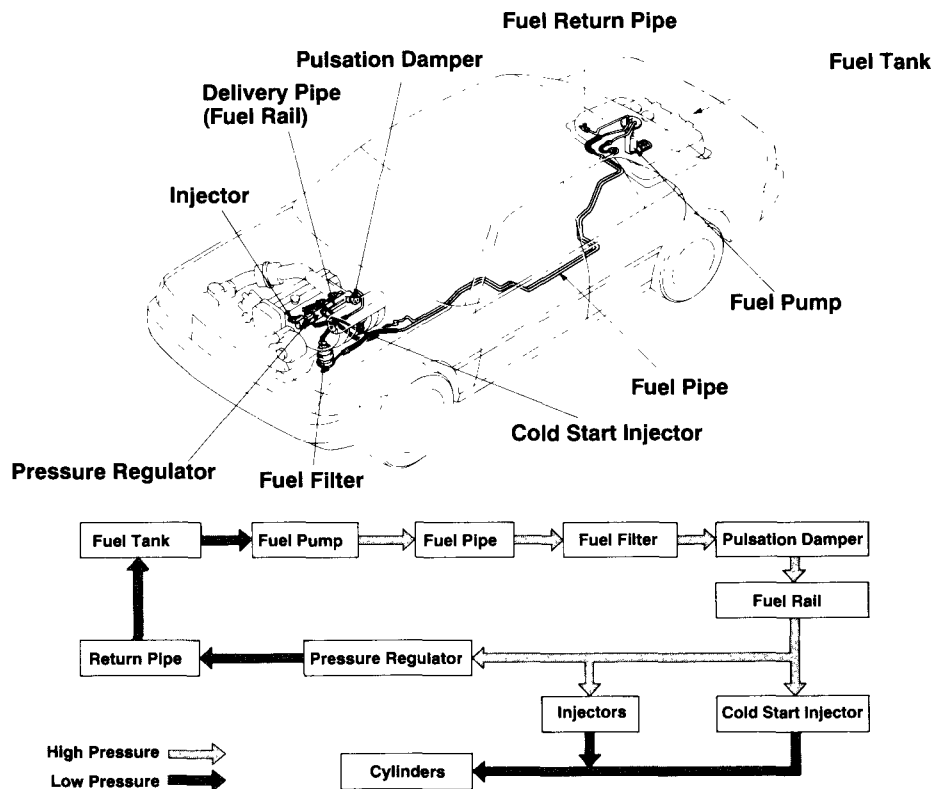

Fuel Delivery and Injection Control Components

Fuel Pumps

Over the years, Toyota has used two types of electric fuel pumps on EFI systems. The early Conventional EFI system used an externally mounted in-line pump. These roller cell pumps incorporate an integral pressure pulse damper or silencer designed to smooth out pressure pulses and provide quiet operation.

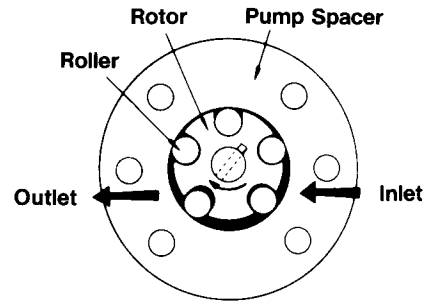

EXTERNAL PUMP DESIGN

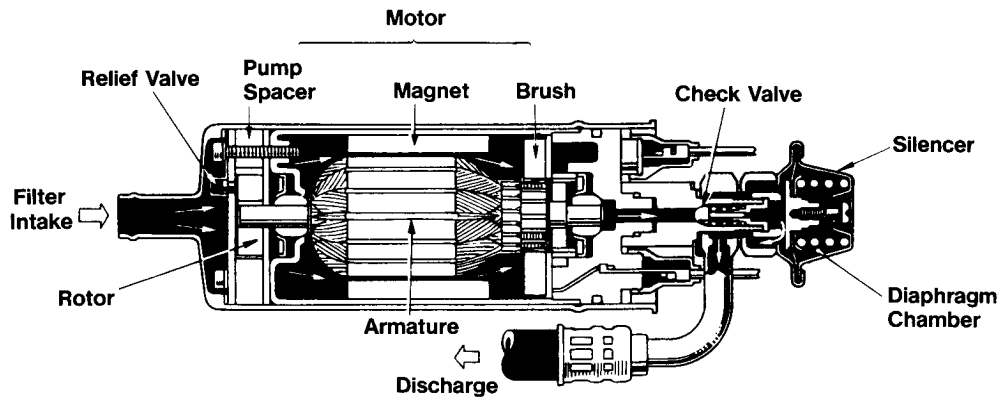

Later model production engines utilize an in-tank pump integrated with the fuel sender unit. These turbine pumps operate with less discharge pulsation and run quieter than the in-line variety. In-tank pumps can be serviced by removing the fuel sender unit from the tank. Make sure that the pump coupling hose is in good condition prior to replacing the pump.

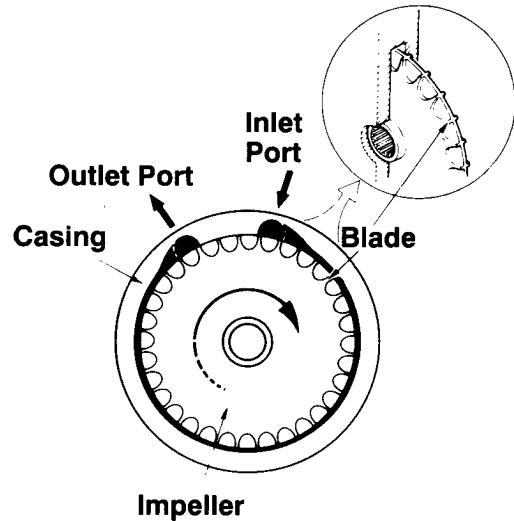
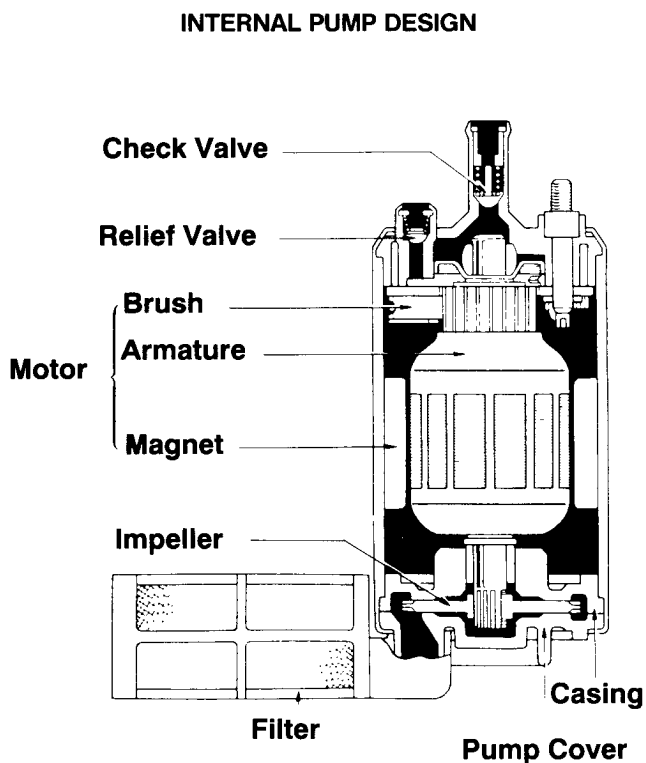

Both pumps share many features. They are referred to as wet pumps because the electric motor operates immersed in fuel. Passing fuel through the pump motor aids in cooling and lubrication.

An outlet check valve is incorporated in the discharge outlet to maintain residual or rest pressure when the engine is turned off. This reduces the possibility of vapor-lock and improves starting characteristics. A pressure relief valve is used to prevent over-pressure and potential fuel leakage in the event that pressure or return lines become restricted.

Fuel Pump Electrical Controls and Circuit Opening Relay

Circuit Opening Relay Circuits There are three types of fuel pump control circuits used on Toyota's EFI engines. One type of control,

used exclusively with L type injection, utilizes the air flow meter Fc contact to complete the circuit opening relay run winding ground. This is a safety feature which prevents the fuel pump from operating when the engine is not running.

CIRCUIT USED WITH L TYPE EFI

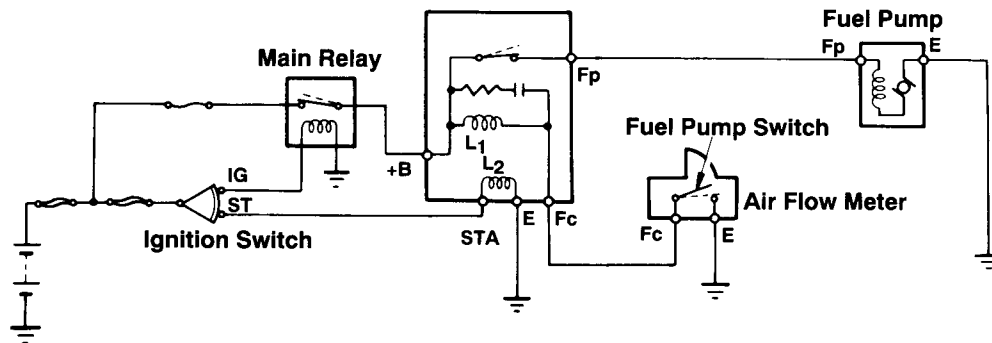

A second type of fuel pump control uses the ECU to control circuit opening relay run winding current. Used on engines equipped with D type EFI and on the 7M-GTE, which uses a Karman vortex air flow meter, this

safety feature prevents fuel pump operation whenever the ECU fails to see an Ne (engine rpm) signal. Under these conditions, the ECU removes ground from the circuit opening relay run winding.

CIRCUIT USED WITH D TYPE EFI (AND 7M-GTE)

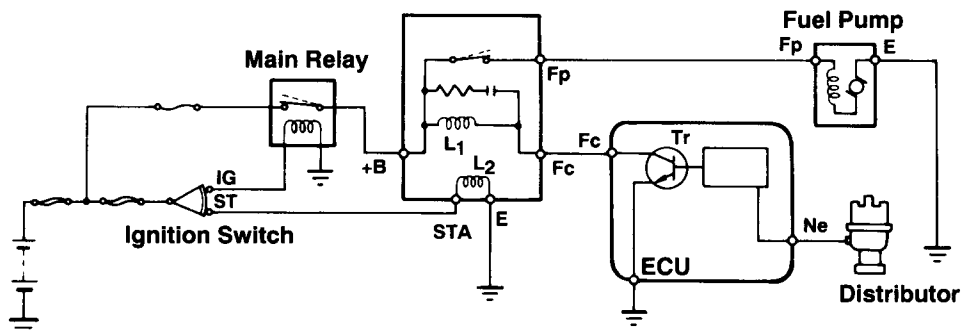

Fuel Pump Speed Control

The third type of fuel pump control circuit utilizes a two-speed pump electrical circuit. Depending upon engine, the circuit opening relay may be driven by the ECU or by the air flow meter Fc contact. Pump current, however, is supplied either through a current limiting resistor or directly to the pump depending on engine load, rpm and status of the STA signal.

When the engine is cranked, or operated at high speed and/or heavy load, the ECU turns off TR1, closing contact A of the Fuel Pump

Control Relay. This allows current to flow directly to the fuel pump, causing it to run at high speed.

Under all other operating conditions, the ECU turns on TR1, which energizes the Fuel Pump Control Relay. This closes relay contact B and forces current to flow through the resistor, causing the pump to run at low speed. The Fuel Pump Speed Control system is designed to reduce electrical demand and pump wear when fuel demand is low while delivering adequate fuel volume when demand is high.

HIGH SPEED OPERATION (RELAY OFF)
(Cranking, High Speed, Heavy Load)

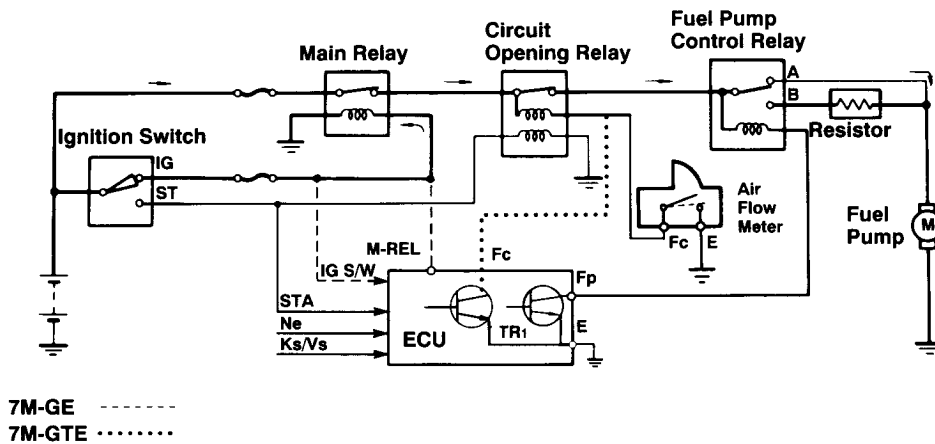

LOW SPEED OPERATION (RELAY ON)
(All Other Operating Conditions)

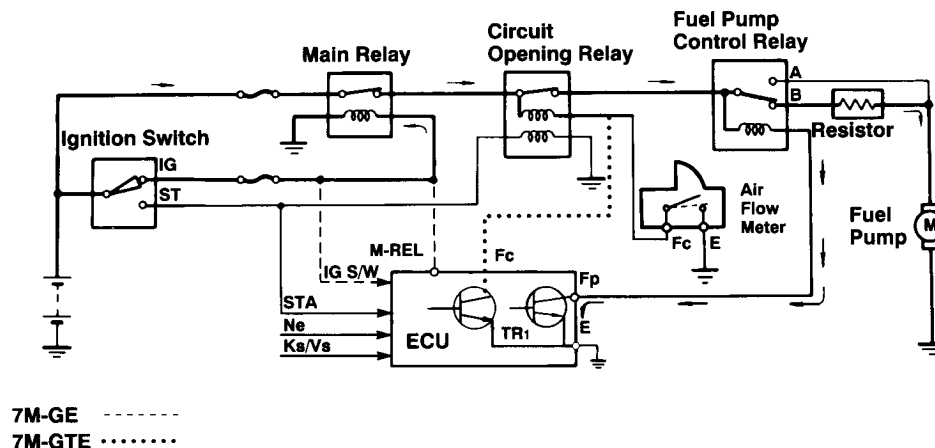

Fuel Pump Test Terminals

To facilitate testing and allow pump operation independent of the air flow meter or ECU control, all engines utilize a fuel pump test connector.

There are two basic types of fuel pump test circuits. Most late model TCCS engines use an Fp test terminal located in the check connector. With the ignition switch on,

jumpering +B to the Fp terminal sends current-directly to the fuel pump.

Earlier engines use a jumper connector referred to as a 2P fuel pump check connector. This connector, when jumpered, supplies ground for the circuit opening relay run winding, allowing it to operate independently of the air flow meter Fc contact.

FUEL PUMP TEST TERMINAL

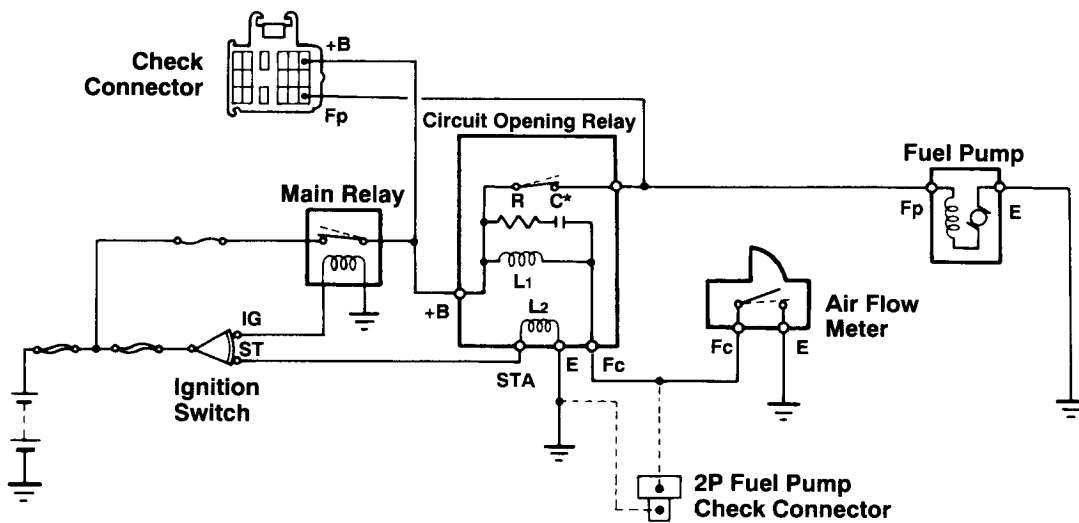

* Some Models Only

Fuel Filter

The fuel filter, which is installed between the pump and the fuel rail, removes dirt and contaminants from the fuel before it is delivered to the injectors and pressure regulator.

Although it is possible for the fuel filter to become contaminated or even completely clogged, this is an unlikely condition because of the high capacity and quality of Toyota's filter. This filter is considered to be maintenance free and no service interval is recommended for periodic replacement.

In the event that this filter becomes restrictive to fuel flow, the engine will suffer from surging, loss of power under load and hard starting problems. If it becomes necessary to replace this filter there are some important safety matters to consider.

Safety tips: When a pressurized fuel line is opened, it poses a fire hazard. Therefore, it is important to relieve fuel system pressure prior to opening the line at the filter. It is also important to disconnect the battery negative cable prior to opening fuel lines due to the proximity of some filters to the +B terminal of the starter.

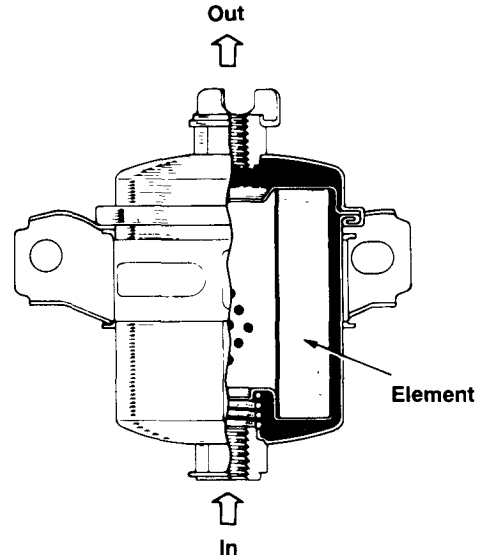

Fuel Delivery Pipe (Fuel Rail)

The fuel delivery pipe, commonly referred to as a fuel rail, is designed to hold the injector in place on the intake manifold. Mounted to the fuel delivery pipe are the pulsation damper (when used) and the fuel pressure regulator. The fuel delivery pipe acts as a reservoir for fuel which is held under pressure prior to delivery by the fuel injector.

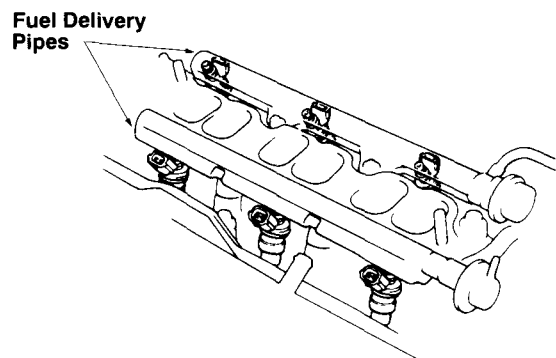

Fuel Pressure Regulator

The fuel pressure regulator is a diaphragm operated pressure relief valve. To maintain precise fuel metering, the fuel pressure regulator maintains a constant pressure differential across the fuel injector. This means that the pressure in the fuel rail will always be at a constant value above manifold absolute pressure.

The specified pressure differential is either 36 PSI (2.55 kg/CM²) or 41 PSI (2.90 kg/CM²) depending on engine application.* Maintenance of this pressure differential is accomplished by balancing a spring, assisted by manifold pressure, against a diaphragm which holds a ball valve on its seat.

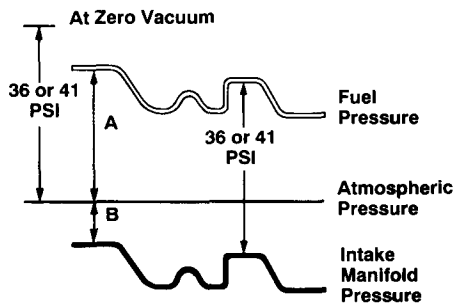
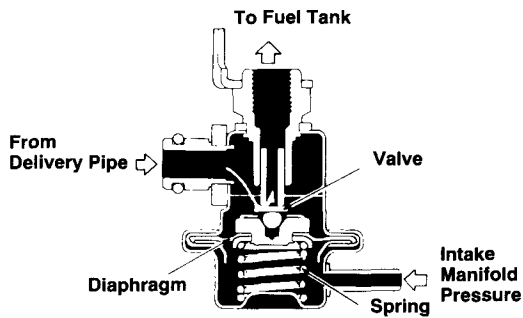

Intake Manifold Pressure	Low	High
Effective Spring Tension	Small	Large
Fuel Pressure	Low	High
Injection Volume	Same	Same

Pulsation Damper

Although fuel pressure is maintained at a constant value by the pressure regulator, the pulsing of the injectors causes minor fluctuations in rail pressure. The pulsation damper acts as an accumulator to smooth out these pulsations, ensuring accurate fuel metering.

The fuel pulsation damper is not used on all engines but can be used as a fuel pressure quick check on those engines which it is used. Noting the diaphragm, when pressure is present, the bolt head in the center of the diaphragm extends out flush with the top of the damper case.

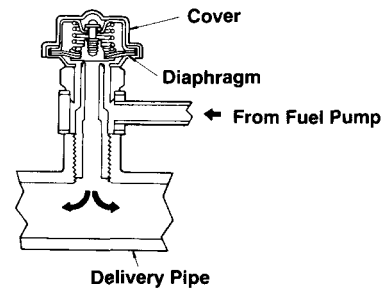

Observe position of bolt head as a quick check for presence of pressure.

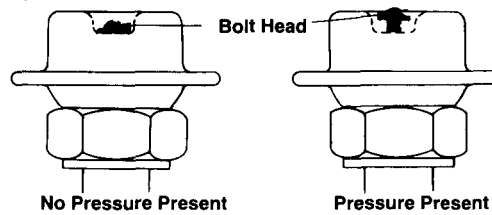

Fuel Pressure Up System

The fuel pressure up system (FPU) is designed to reduce the possibility of vapor formation in the fuel rail after hot soak and is used on many TCCS engines. It utilizes an ECU controlled Vacuum Switching Valve (VSV) to open an atmospheric bleed into the manifold reference line to the fuel pressure regulator.

This solenoid is energized during hot engine cranking and for up to two minutes after the engine starts. The ECU grounds the FPU

VSV based on input received from STA and THW signals. Energizing the solenoid bleeds atmospheric pressure into the fuel pressure regulator vacuum chamber increasing fuel rail pressure to its maximum level.

On some engines, the ECU also monitors engine load and rpm signals (Vs, PIM and Ne) and energizes the VSV under heavy load and high rpm operation to ensure maximum fuel rail pressure.

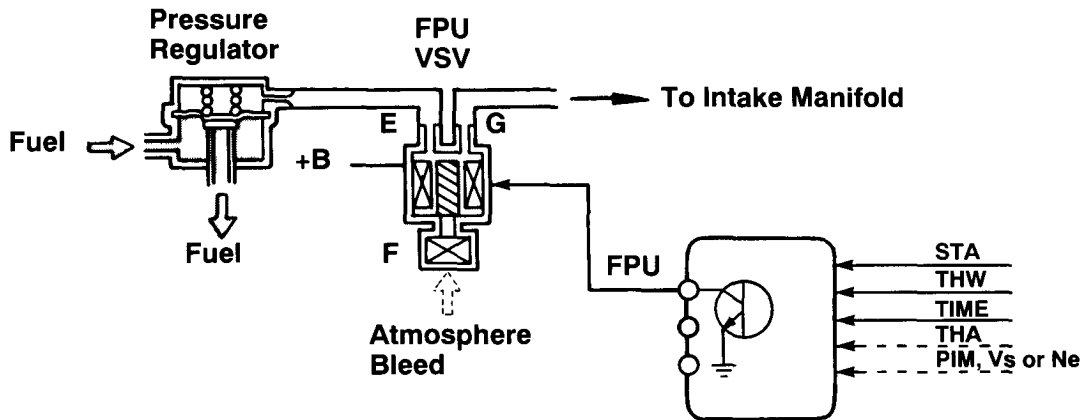

Engine Condition	VSV	Port E	Port G	Bleed Port F
<ul style="list-style-type: none"> • Cranking • ≤ 2 min. after hot restart • Heavy load, high speed* 	ON	○	○	○
Normal Driving Conditions	OFF	○	○	○

* Some Engines Only

Fuel Pressure and Volume Testing

Safety Tips: Prior to installing a fuel pressure gauge and checking fuel pressure, residual pressure must be safely relieved to reduce the hazard of fire when the fuel line is opened. It is advisable to have a fire extinguisher whenever opening the fuel system.

Common gauge hookup locations are at the fuel rail, fuel filter, or the cold start valve using SST #09268-45012 and #09268-45013-01. Repair manual procedures should always be followed. Whenever a fuel hose connection secured with a copper sealing gasket is opened, a new gasket should be used when the hose is re-secured after service.

Fuel pressure and volume tests can be divided into six separate areas.

The following tests and specifications are general guidelines; consult the repair manual for actual specifications and procedures.

Test Condition	A Type (36 PSI)		B Type (41 PSI)	
	Min.	Max.	Min.	Max.
Engine Cranking	33 PSI	40 PSI	38 PSI	46 PSI
Engine Running (Regulator hose connected)	23 PSI	30 PSI	33 PSI	37 PSI
Engine Running (Regulator hose disconnected)	33 PSI	40 PSI	38 PSI	46 PSI
Engine Off Residual Pressure (after 5 minutes)	≥ 21 PSI		≥ 21 PSI	
Maximum Pump Pressure* (pressure relief point)	50 PSI	85 PSI	50 PSI	85 PSI
Minimum Delivery Volume (after 30 seconds)	1 liter		1 liter	

CAUTION: Perform this test only long enough to determine if pressure rises above minimum specification; risk exists of blowing coupler hose off of pump. This test is only necessary if other pressure tests indicate lower than normal fuel pressure.

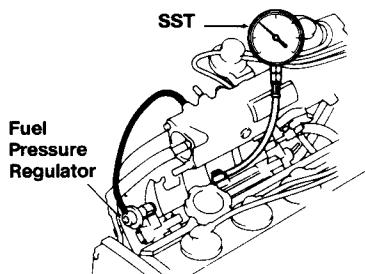

Fuel Injectors

The fuel injector is an electro-mechanical device which meters, atomizes and directs fuel into the intake manifold based on signals from the ECU driver circuit(s). All Toyota engines used in the U.S.A. position the injectors, one per cylinder, directly behind the intake valve. The injectors are installed with an insulator/seal on the manifold end to isolate the injector from heat and to prevent an atmospheric pressure leak into the manifold. The fuel delivery pipe serves to secure the injector in place. Fuel is sealed on the delivery pipe end by an O-ring and grommet.

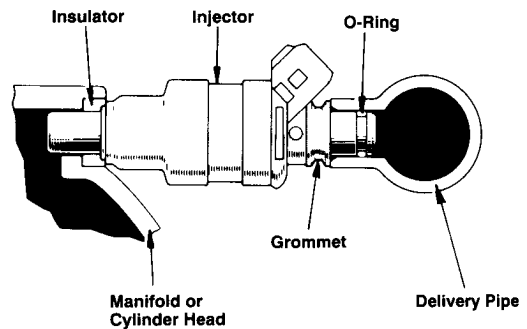

To reduce the possibility of vapor lock, which tends to occur during high temperature operation, the 3S-GTE and 2TZ-FE engines use a side feed injector. This type of injector seals with an upper and lower O-ring. O-rings and insulators should always be replaced when injectors are removed; they should never be re-used.

SIDE FEED INJECTOR

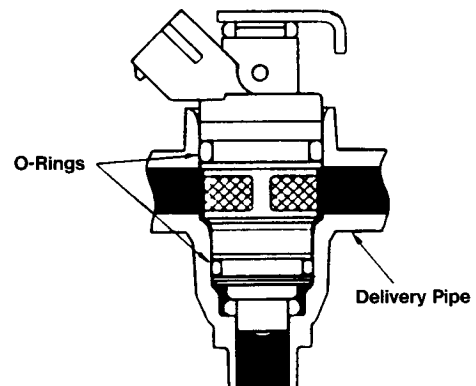

Air Assist System

To promote better fuel atomization, the 3VZ-FE engine uses an air assist system which meters air from the Idle Speed Control (ISC) valve directly to the nozzle of the fuel injector.

An adaptor for the air assist system is added to a standard two-hole type injector to provide an air distribution gallery. Air is mixed with fuel in the chamber formed by the injector insulator grommet and the lower O-ring.

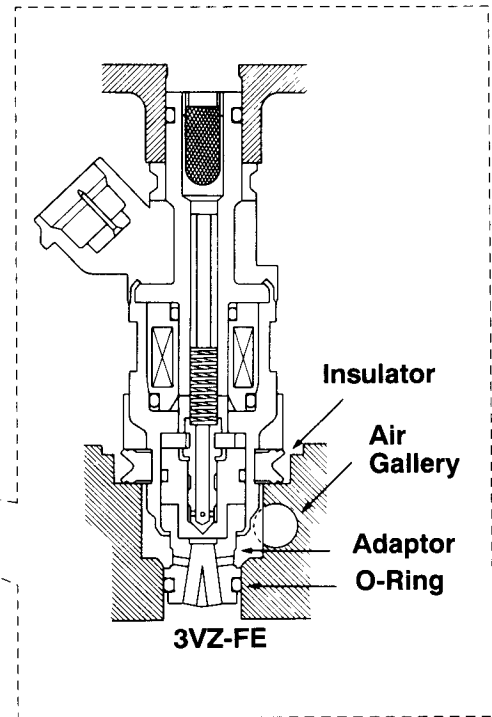
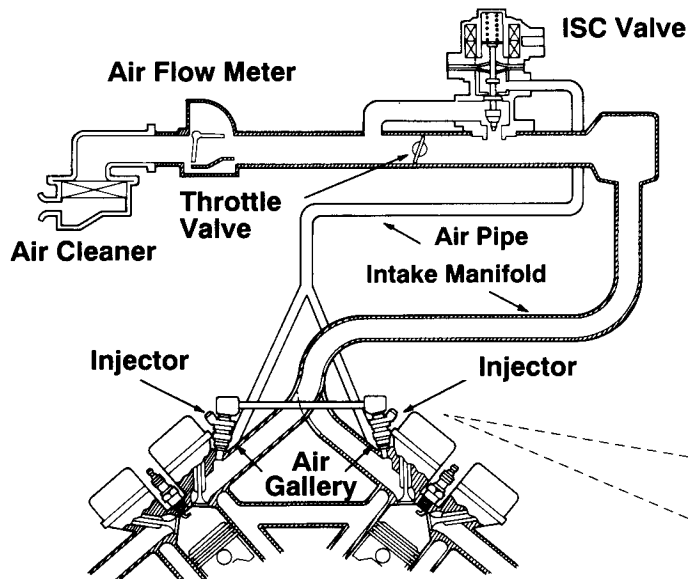

Types Of Injectors In Use

Toyota currently uses four different types of fuel injectors depending on engine application. These can be broken down into pintle type and hole type (cone valve and ball valve), high resistance and low resistance.

Pintle Type Injector - This was the original design used on early Conventional and EFI/TCCS engines. This injector gets its name from the type of valve used to control fuel atomization and flow. It offers good atomization of fuel but is susceptible to deposit buildup on the pintle valve. Deposits cause restriction to fuel flow promoting lean fuel delivery and altered injector spray pattern.





Hole Type Injector - Hole type injectors were introduced on later model EFI/TCCS engines to reduce concerns with injector deposits. The injection valve is recessed from the tip of the injector and fuel is delivered through holes drilled in a director plate at the injector tip. The hole type injector offers good fuel

atomization while demonstrating better resistance to deposit buildup compared to the pintle design. There are currently three designs of hole type injectors in use, including a side feed injector used on the 3S-GTE and 2TZ-FE engines.

High And Low Resistance Injector Windings
There are two different types of injector coil windings used depending on the type of drive circuit used and whether or not an external resistor is being used.

Low resistance injectors, which typically range between 2 - 3 Ω @ 70°F, are used with an external resistor in a voltage controlled driver circuit. Low resistance injectors are also used without an external resistor in a current controlled driver circuit.

High resistance injectors, which typically run about 13.8 Ω @ 70°F, do not require the use of an external resistor in a voltage controlled driver circuit.

Connector Shape	Shape of Injection Port	Resistance Value	EFI Inspection Wire (SST)
	Pintle Type	Low	C with resistor 09842-30020
	Pintle Type	High	D without resistor 09842-30040
	Hole Type	Low	E with resistor 09842-30060
	Hole Type	High	F without resistor 09842-30070

Pintle Type

Hole Type (ND)

Hole Type (AISAN)

Side Feed
Hole Type (AISAN)

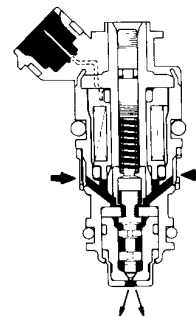
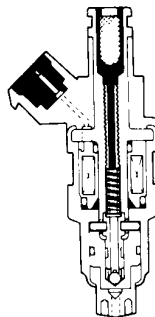
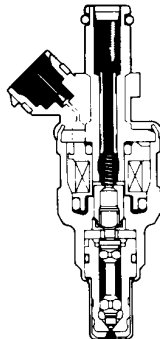
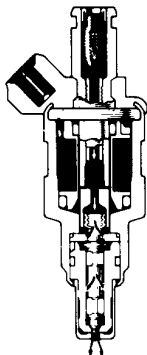

Injector Driver Circuits

Current is supplied to the ECU driver circuits (#10 and #20 in example) through the fuel injectors. Current flows either directly from the ignition switch or from the EFI Main Relay. When the ECU driver circuit turns on, current flows to ground through the injector solenoid coil. The magnetic field created causes the injector to open against spring tension. When the ECU driver circuit turns off, the spring closes the injector valve.

There are two common types of driver circuits currently in use on Toyota EFI engines; both of these driver circuits work on the voltage control principle. One uses an external solenoid resistor and a low resistance injector, the other using a high resistance injector without the solenoid resistor. In both cases, the high circuit resistance is required to limit current flow through the injector winding. Without this control of the current flow through the injector, the solenoid coil would overheat, causing injector failure.

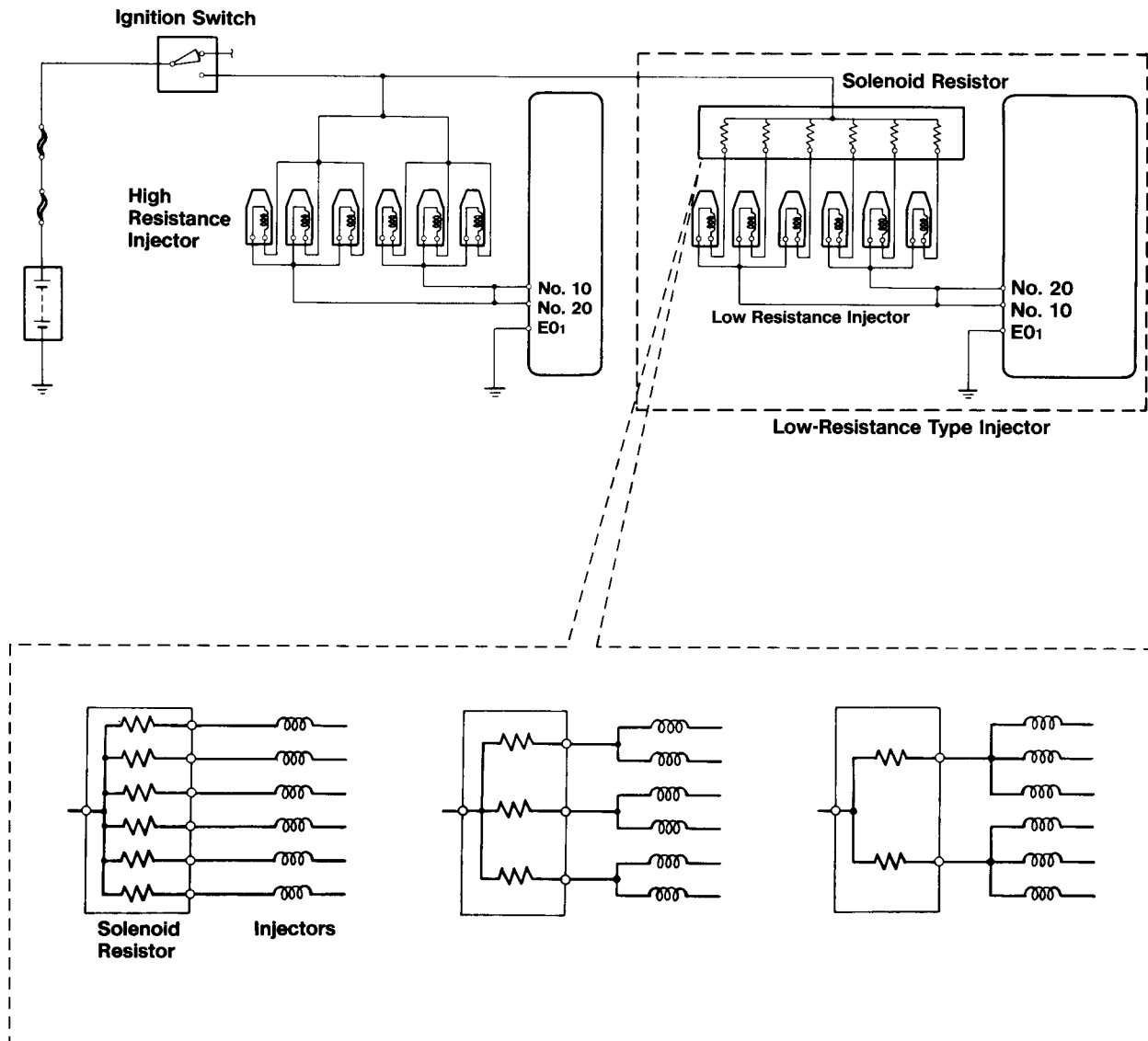

EFI #3 - FUEL DELIVERY & INJECTION CONTROL

A third type of driver circuit was used by Toyota on overseas models using the 4A-GE engine with D type EFI. Referred to as a current controlled driver circuit, it has never been used by Toyota on vehicles sold in the U.S.A. but is widely used by other auto manufacturers. This type of driver circuit uses a low resistance injector and limits current flow by controlling the gain of the driver transistor. The advantage to the current controlled driver circuit is the short time period from when the driver transistor goes on to when the injector actually opens. This is a function of the speed with which current flow reaches its peak.

In terms of injection opening time, the external resistor voltage controlled circuit is somewhat faster than the voltage controlled high resistance injector circuit. The trend, however, seems to be moving toward use of this latter type of circuit due to its lower cost and reliability. The ECU can compensate for slower opening time by increasing injector pulse width accordingly.

Caution: Never apply battery voltage directly across a low resistance injector. This will cause injector damage from solenoid coil overheating. Use the proper SST inspection wire will ensure proper series resistance.

VOLTAGE-CONTROLLED TYPE

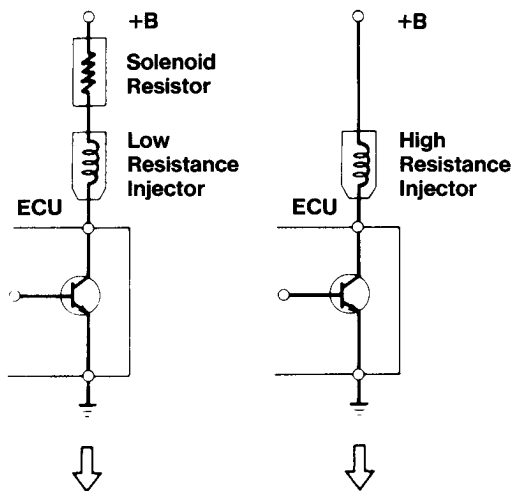

CURRENT-CONTROLLED TYPE

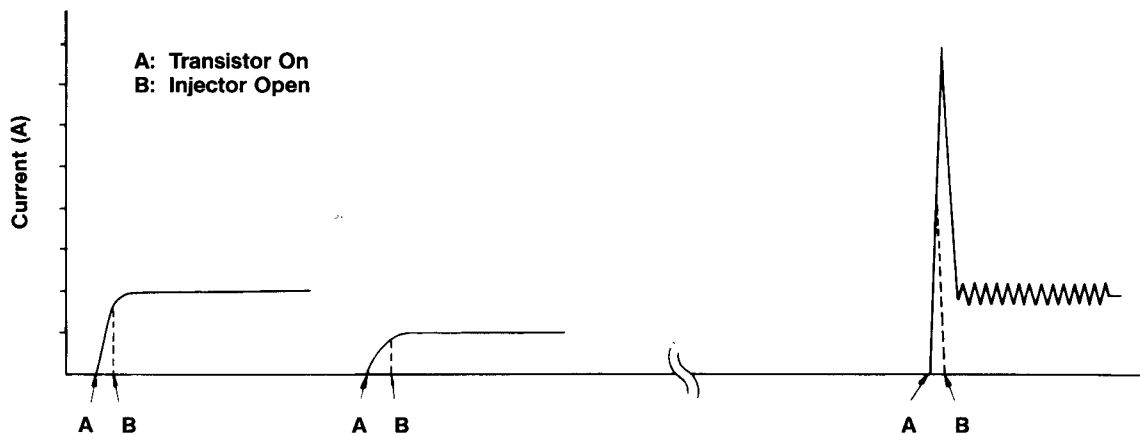
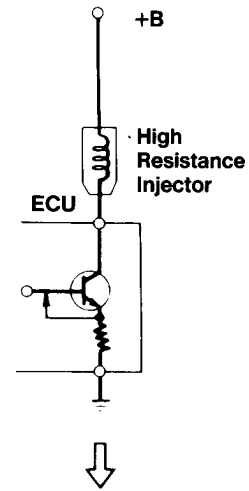

Fuel Injection Pattern and Injection Timing

Fuel injectors can be pulsed in one of four patterns depending on application. These injection patterns are:

- Simultaneous
- Two groups of two injectors each (four cylinder engines)
- Three groups of two injectors each (six cylinder engines)
- Independent (sequential)

The following chart represents fuel injection grouping and timing patterns.

Because injection timing is based on engine rpm, the ECU must receive an rpm signal to operate the injector driver circuits. With Conventional EFI, this signal comes directly from the coil and is identified as IG. With TCCS, the rpm and crankshaft position identification signals come from the Ne and G1 sensors located in the distributor. If these signals are lost, the ECU will not pulse the injectors.

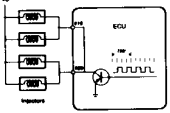
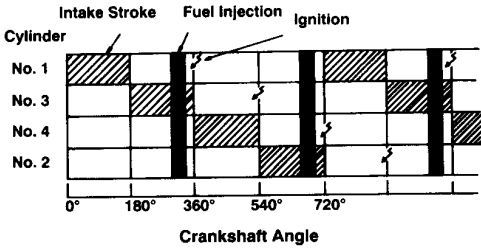
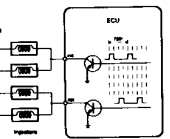
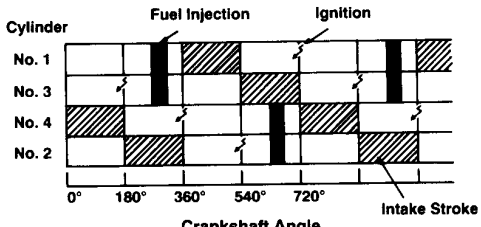
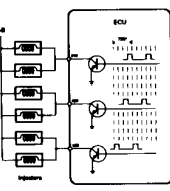
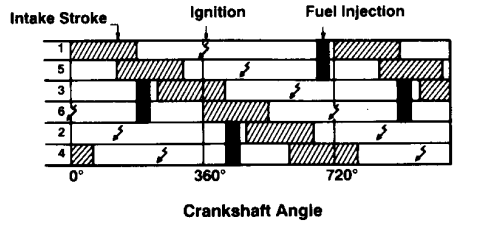
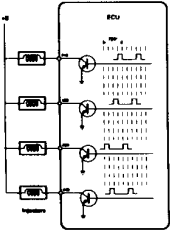
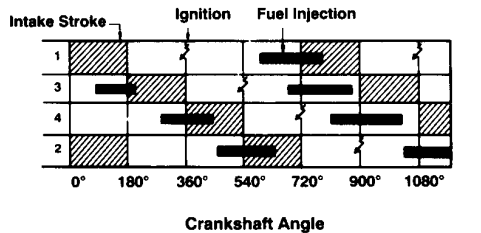
Injection Pattern	Injection Timing	Engines
<p>Simultaneous</p> 	 <p style="text-align: center;">Crankshaft Angle</p>	<p>4K-E, 4A-FE 2S-E, 3S-FE, 5S-FE (GEN 1) 4M-E, 5M-E, 5M-GE, 3Y-E, 4Y-E 22R-E, 22R-TE 3VZ-E, 3F-E 3E-E</p>
<p>2 Groups</p> 	 <p style="text-align: center;">Crankshaft Angle</p>	<p>4A-GE (L type EFI) 4A-GZE 5S-FE (GEN 2) 5E-FE</p>
<p>3 Groups</p> 	 <p style="text-align: center;">Crankshaft Angle</p>	<p>7M-GE 7M-GTE 2VZ-FE</p>
<p>Independent</p> 	 <p style="text-align: center;">Crankshaft Angle</p>	<p>3S-GE 3S-GTE 3VZ-FE</p>

Fuel Injection Volume

Fuel injection volume determination is based upon the value of input sensor signals. In addition to volume control, the ECU can pulse the injectors either synchronously or non-synchronously with ignition events. Both of these topics will be addressed in Chapter 5, "The Electronic Control System."

Common Service Concerns and Solutions

Injector Maintenance and Cleaning

Although it is not the problem it was back in the early to mid '80s, fuel injector restriction is still an issue which needs to be addressed from both a preventative maintenance and repair viewpoint.

The best method of injector maintenance is continuous use of high quality fuels with a level of detergency adequate to keep the injector nozzles clean. It is also prudent to offer injector cleaning service using the Toyota approved injector cleaning system and solvents. This service can be offered whenever the vehicle is in for major service to maintain good engine performance and reduce the possibility of expensive injector replacement due to nozzle build-up.

It has been established that engines using hole type injectors tend to have fewer problems with fouling than those with pintle type injectors. It has also been established that use of low quality fuels which lack adequate detergent additives can lead to injectors which become flow restrictive or which develop poor spray patterns.

When an injector becomes flow restricted, the volume of fuel delivered for a given injection duration will be reduced. This condition will cause lean driveability problems like stumble, hesitation, backfire and surging, especially during open loop operation.

When an injector develops a poor spray pattern, fuel is not atomized and vaporized properly. It is entirely possible that the correct volume of fuel will be delivered to the intake manifold, however, this fuel will enter the cylinder as liquid droplets and will not burn. This condition will cause increased hydrocarbon emissions and lean driveability problems just as if the fuel delivery were lean. The symptoms of poor spray pattern can be very similar to those of flow restricted injectors.

When it comes time to diagnose these two problems, the recommended procedure is to remove the injectors from the engine and bench flow test each injector using the following tools. This procedure is covered in detail in the appropriate repair manuals.

The following information covers the general test procedure.

Tool Name	SST Number	Purpose
Filter union and hose	#09268-41045	Adapts fuel filter on vehicle to test apparatus
Pressure regulator union	#09268-41045	Adapts regulator on vehicle to test apparatus
Union and clamp	#09268-41045	Adapts removed injector to test apparatus
Test harness	#09843-18020	Jumper +B to FP terminal
Test harness	#09842-30020 #09842-30040 #09842-30060 #09842-30070	Makes electrical connection to injector
Graduated cylinder, minimum 500 cc volume	NPN, purchase locally	Measure fuel delivery

EFI #3 - FUEL DELIVERY & INJECTION CONTROL

1) Assemble SST as shown below.

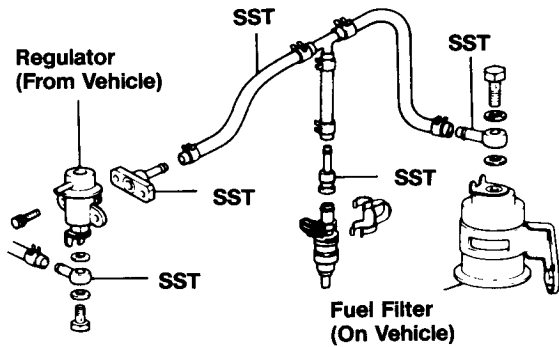

2) Using correct inspection harness, energize injector for specified number of seconds. Observe spray pattern and compare relative fuel delivery volume with specifications.

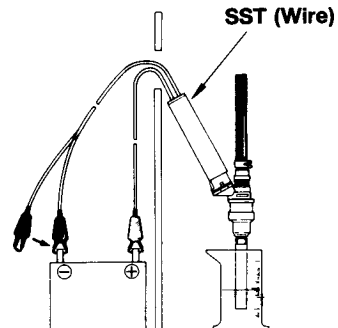

Caution: Do not create sparks near fuel injector and graduated cylinder. Keep fire extinguisher nearby while performing this test.

3) Compare injection spray pattern to standard.

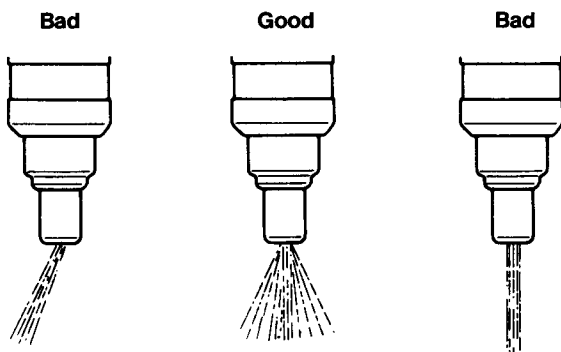

Check Spray Pattern

4) Check injector for leaks.

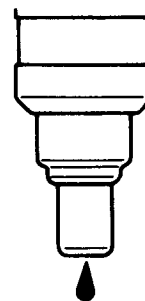

**< 1 Drop Per Minute
Check For Leaks**

Fuel Starvation Under Load

When troubleshooting performance problems which are related to insufficient fuel delivery, the fuel pickup filter should not be overlooked as one possible source of restriction. Contaminants in fuels can restrict this in tank filter sufficiently to cause engine performance problems. In many cases, the engine will perform normally under light load conditions.

The in-line filter, although considered to be a "lifetime" filter, can also cause fuel starvation under load and hard starting if it becomes restricted.

The best method of diagnosing suspected fuel starvation which takes place under load conditions is road testing with a fuel pressure monitor safely installed on the vehicle.

Injector Installation Cautions

It is very important to use new O-rings and grommets when installing injectors to prevent leakage of fuel and potential air leaks into the manifold. O-rings should be

lubricated with gasoline during installation and injectors should be checked for smooth rotation once installed to ensure proper seating.

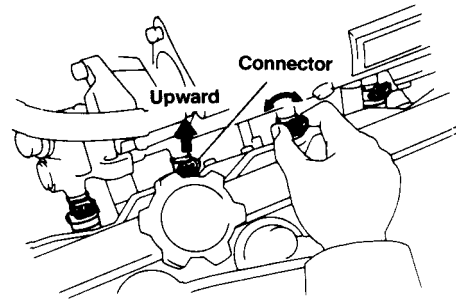

Finally, many applications use a bi-directional spray pattern which requires precise positioning of the injector in relation to the cylinder head. Use care to follow proper procedures outlined in the appropriate repair manual.

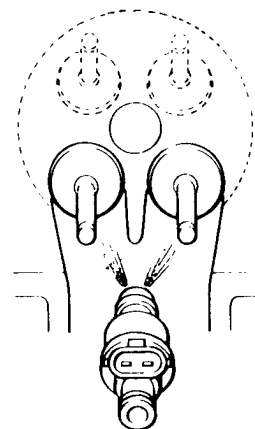
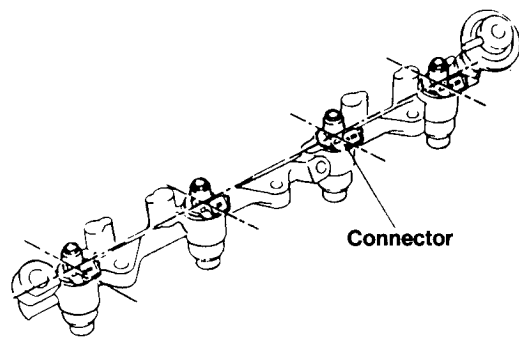
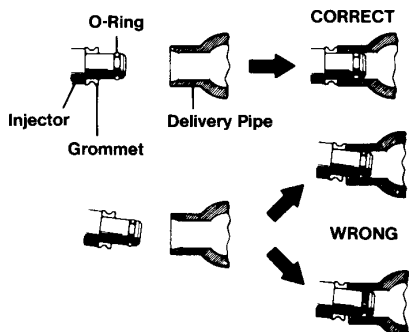
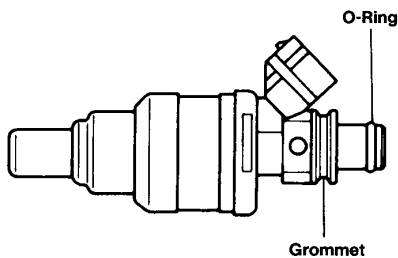

Injector Placement

Placement of injectors by cylinder is not usually necessary; however, starting with the 1991 Tercel 3E-E engine, injectors with two different hole placements are used. The injectors from cylinders number 1 and 3 are not interchangeable with those installed in cylinders number 2 and 4.

Always refer to the appropriate repair manual before installing the injectors on the 3E-E or any other engine as this will ensure correct installation. Failure to properly install and position injectors can cause subtle driveability problems which may be difficult to find after the fact.

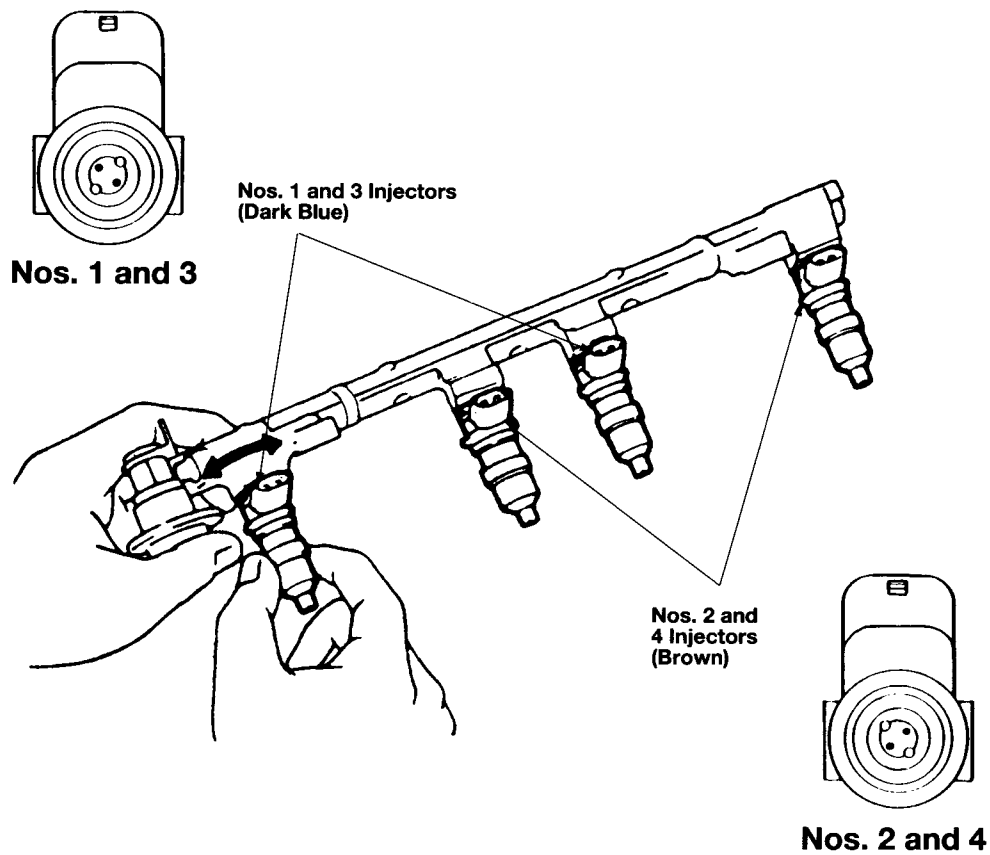

Cold Start Injection System

To improve engine starting when coolant temperatures are low, a supplementary injector is installed on many EFI engines. The cold start injection system consists of the following components:

- 1) Cold Start Injector
- 2) Start Injector Time Switch
- 3) ECU (most EFI/TCCS)

Cold Start Injector

The cold start injector is located at some central location in the intake manifold. It is designed to supplement the cranking air/fuel ratio and prime the intake manifold in much the same way as a choke valve does while cranking a carbureted engine.

This injector, controlled by the start injector time switch and ECU, sprays a finely atomized mist of fuel while the engine is cranked to improve the speed with which the engine starts. To prevent engine flooding, the injection time is limited by calibration of the start injector time switch and a timer in the ECU.

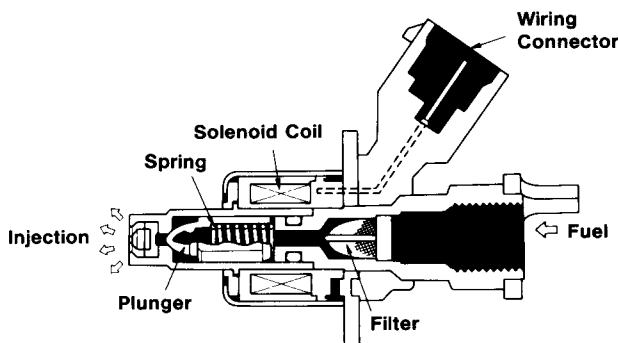

Start Injector Time Switch

The function of the start injector time switch is to control the cold start injector ground circuit and to determine maximum injection duration while cranking. Its bi-metallic switch is heated by both engine coolant and an electrical heater.

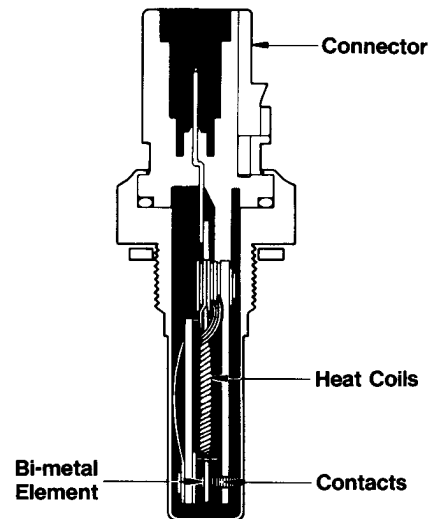

When the engine is cranked, current flows from the STA circuit of the ignition switch to the cold start injector. Current also flows to the heater coils of the start injector time switch. When the bi-metallic contact of the start injector time switch is closed, current flows through the STJ circuit to ground, causing the cold start injector to deliver fuel.

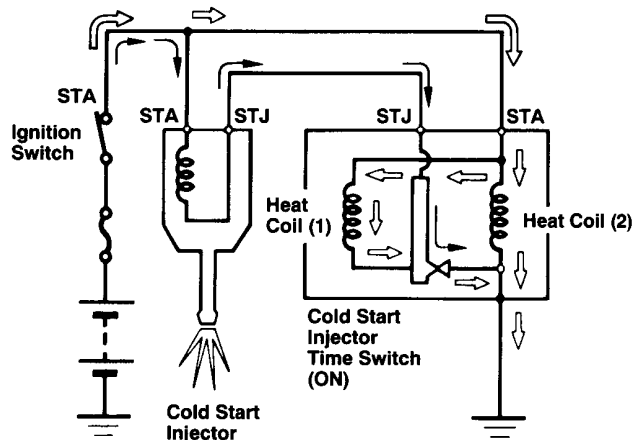

EFI #3 - FUEL DELIVERY & INJECTION CONTROL

As the bi-metallic switch is heated by electric current, it opens, causing the STJ circuit to be broken. This prevents the cold start injector from delivering fuel.

Heater coils 1 and 2 are wired to accommodate heater current flow whether or not the time switch is closed.

The start injector time switch comes in several calibration values. These values determine the maximum temperature and maximum time that the switch will remain closed while the engine is being cranked. Specifications for switch calibration are stamped on the switch. Application information is available through parts and technical service bulletins.

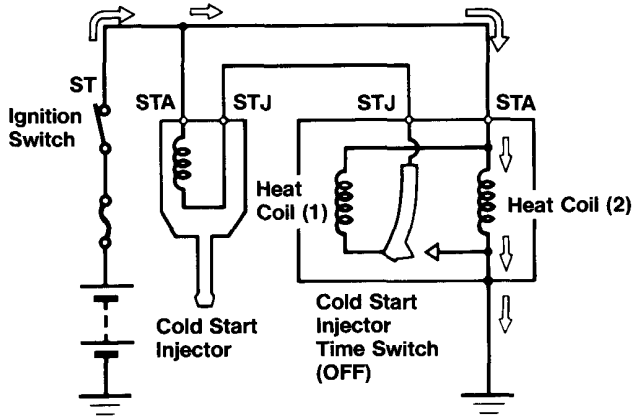

When the time switch contact is open, current can still flow through Heat Coil 2, thereby preventing the contact from closing in the middle of a cranking cycle.

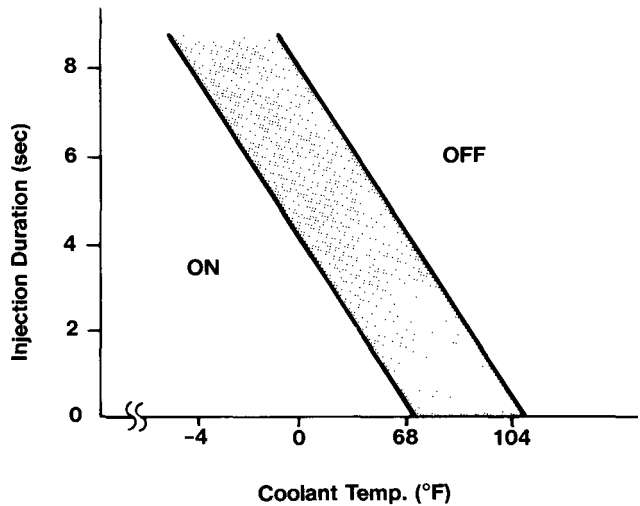

On or off depending on engine model

ECU Cold Start Injector Control

On most TCCS engines, an alternate ground may be supplied to the cold start injector by the ECU at the STJ terminal. Based on signals from the coolant temperature sensor, the ECU can operate the cold start

injector for up to three seconds regardless of the status of the time switch. Maximum coolant temperature for ECU control is 113°F (45°C), above which the cold start injector will not operate from any source.

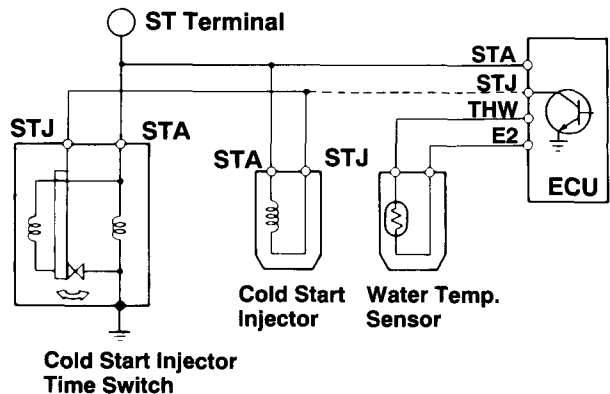
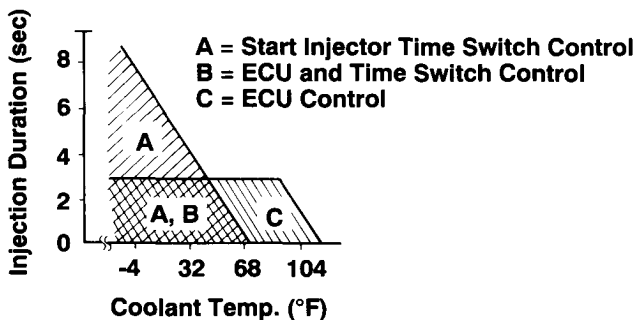

Alternative Method of Cold Cranking Enrichment

Some engines have eliminated use of a cold start injector entirely. Starting with the '91 model year, cold start injectors have been eliminated on the 3E-E and 4A-FE engine. During cranking, the ECU looks at THW and lengthens injector pulse width sufficiently to start the engine.

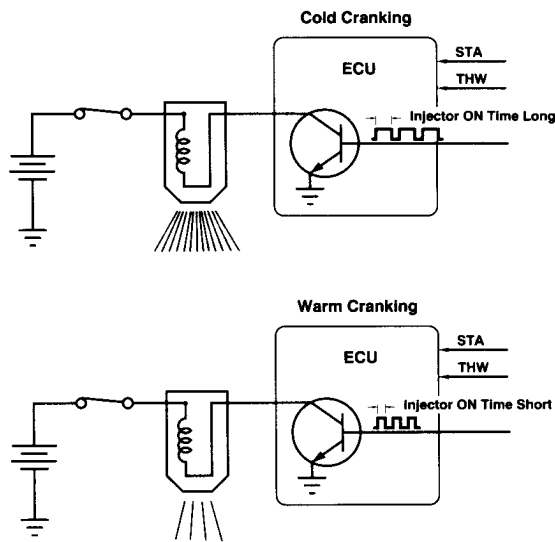

Summary

In this chapter you have learned that the fuel delivery system pumps fuel from the tank to the engine where it is delivered by an electronically controlled fuel injector.

The fuel pump delivers fuel with enough pressure and volume so the fuel pressure regulator can hold a constant pressure differential between intake manifold and fuel rail. Fuel which is delivered to the fuel rail but not injected into the cylinders is returned to the tank through a return pipe.

The fuel pump is energized by the circuit opening relay electrical circuit whenever the ignition switch is on and the engine is running or cranking. Depending on fuel demand, some pumps are operated at two speeds by routing current flow through or around a special current limiting resistor. The fuel pump electrical circuit has a diagnostic monitor built into the underhood check connector for diagnosis and testing.

Fuel injectors are electrically controlled by the ECU and are driven individually, in groups, or simultaneously, depending on engine application. Current flow through the injector coil is controlled by using a high resistance coil or a separate injector solenoid resistor.

To improve cold starting, some engines are equipped with a cold start injector system which is controlled by a start time switch and/or the ECU.

Reprinted with permission from Toyota Motor Sale, U.S.A., Inc. from #850 EFI Course Book.